



HARDWARE GUIDE

Rooftop Controller C1000 Series

Specifications and Operational Guide

www.proloncontrols.com | info@proloncontrols.com
17 510, rue Charles, Suite 100, Mirabel, QC, J7J 1X9



Table of Contents

General Information	4
PL-C1000 Basic Rooftop Controller.....	4
Description.....	4
General Behaviour	4
Operating Sequence	5
General.....	5
Occupied Mode.....	5
Unoccupied Mode.....	5
Components	6
Component Identification	6
LEDs.....	7
Addressing Dipswitch Configuration for Network Communication	7
Jumper to Supply Power to the RJ45 Plug.....	8
Input and Output Identification.....	8
Inputs	9
Temperature Sensors.....	9
Occupancy Mode (<i>Night Setback</i>)	10
Proof of Fan.....	10
Outputs	11
Output Specifications.....	11
Typical Connection of the Triac Outputs 1 through 4.....	12
Typical Connection of Output #5.....	12
DMUX-4J Connection on Output 2 for Stage 3 or 4 Cooling	13
PTA2 Connection on Output 2 for Analog Cooling	14
Power Source & Network	15
Power Source.....	15
Network Communication.....	15
Technical Specifications	16
Compliance	17
FCC User Information.....	17
Industry Canada	17
Overall Dimensions	18



Table of Figures

Figure 1 - Component Identification	6
Figure 2 - LEDs Identification	7
Figure 3 - Addressing Dipswitches	7
Figure 4 - RJ45 Jumper	8
Figure 5 - Input and Output Identification	8
Figure 6 - RJ45 Pinout	8
Figure 7 - Connecting the Sensors	9
Figure 8 - Night Setback Contact Connection.....	10
Figure 9 - Connecting the Proof of Fan Contact to the Controller	10
Figure 10 - Connection of Outputs 3 and 4.....	12
Figure 11 - Connecting the Analog Output (External Power)	12
Figure 12 - Connecting the DMUX-4J (Powered by C1000)	13
Figure 13 - Connecting the PTA2 (Powered by C1000).....	14
Figure 14 - Connecting the 24VAC Power Source	15
Figure 15 - Connecting to the Network	15
Figure 16 - C1000 Size Diagram	18



PL-C1000 Basic Rooftop Controller

Description

The Prolon C1000 Basic Rooftop is a microprocessor-based controller designed to operate rooftops or other mechanical HVAC systems. It acts as a master when used on a network with other Prolon zone controllers.

General Behaviour

Although fully programmable, the Prolon C1000 Basic Rooftop controller uses pre-established control sequences or “profiles” to operate specific HVAC equipment with dedicated output functions. Those can be fully optimized to obtain the best results for each type of system. Numerous parameters enable the modification or fine tuning of the fan, the cooling outputs, the action of the heating outputs (On-or-Off / pulsed / modulating), the proportional bands, integration times, differentials, operational ranges, setpoints and a whole range of limits and safeguards. The various programming options also allow the user to modify the unoccupied mode settings, morning warm-up and supply air pre-heating sequences as well as each zone weight and network demand control strategy best suited for the building space it is controlling. All these parameters can be accessed by using the Prolon Focus software.





Operating Sequence

General

The Proton C1000 Basic Rooftop controller receives readings from three temperature sensors located outside, in the return duct and in the supply duct. Also, as a Master device, it receives data from the zone controllers sent on the network bus. A dry contact originating from an external timer signals the occupancy status (optional) to the Master. The controller then analyzes all the data and demands sent by the zones and commands the appropriate outputs to respond accordingly, within parameters set by the temperature sensors and other safety limits. The Master sends back information on its network such as supply air temperature, occupancy status and other relevant data for the zone controllers to use.

Occupied Mode

The controller operates the fan. When there is a cooling demand from the zones, the Rooftop controller will activate the cooling outputs as long as all temperature limits, delays and other related parameters are respected. Once the demand is satisfied, the outputs are deactivated within the prescribed minimum on/off time delays.

When there is a heating demand from the zones, the Rooftop controller will activate the heating outputs as long as all temperature limits, delays and other related parameters are respected. Once the demand is satisfied, the outputs are deactivated within the prescribed minimum on/off time delays.

When there is no cooling or heating demand from the zones, only the fan is enabled. If the heating equipment permits, a supply air pre-heating sequence may be enabled. This allows cold mixed air to be heated to a more comfortable level for subsequent use by the zones for ventilation.

Unoccupied Mode

The fan can be configured to operate in intermittent mode. When there is a cooling or heating demand from any single zone, the Rooftop controller will activate the fan and the cooling outputs as long as all temperature limits, delays and other related parameter are respected. Once the demand is satisfied, the fan and cooling outputs are deactivated within the minimum on/off time delays set.

During the unoccupied period, the Rooftop controller can be driven by the highest demand on the network and will operate the fan and relevant outputs accordingly.



Component Identification

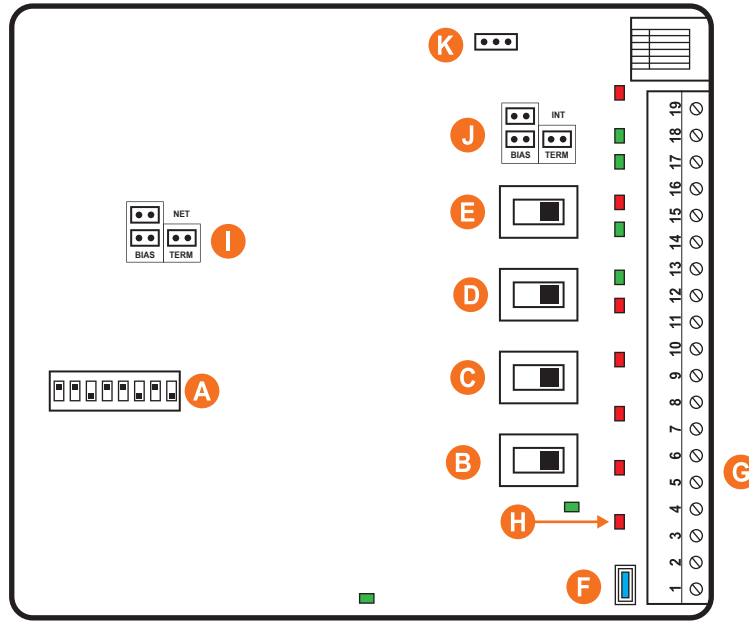

Figure 1 - Component Identification

Legend:

- A - Addressing DIP switch
- B - Output 1 DIP switch
- C - Output 2 DIP switch
- D - Output 3 DIP switch
- E - Output 4 DIP switch
- F - Master reset button
- G - Terminal Blocks for Inputs and Outputs
- H - LEDs
- I - Jumpers for terminating and bias resistors for the NET port
- J - Jumpers for terminating and bias resistors for the INT port
- K - Jumper to supply voltage to INT port (RJ45 jack)



LEDs

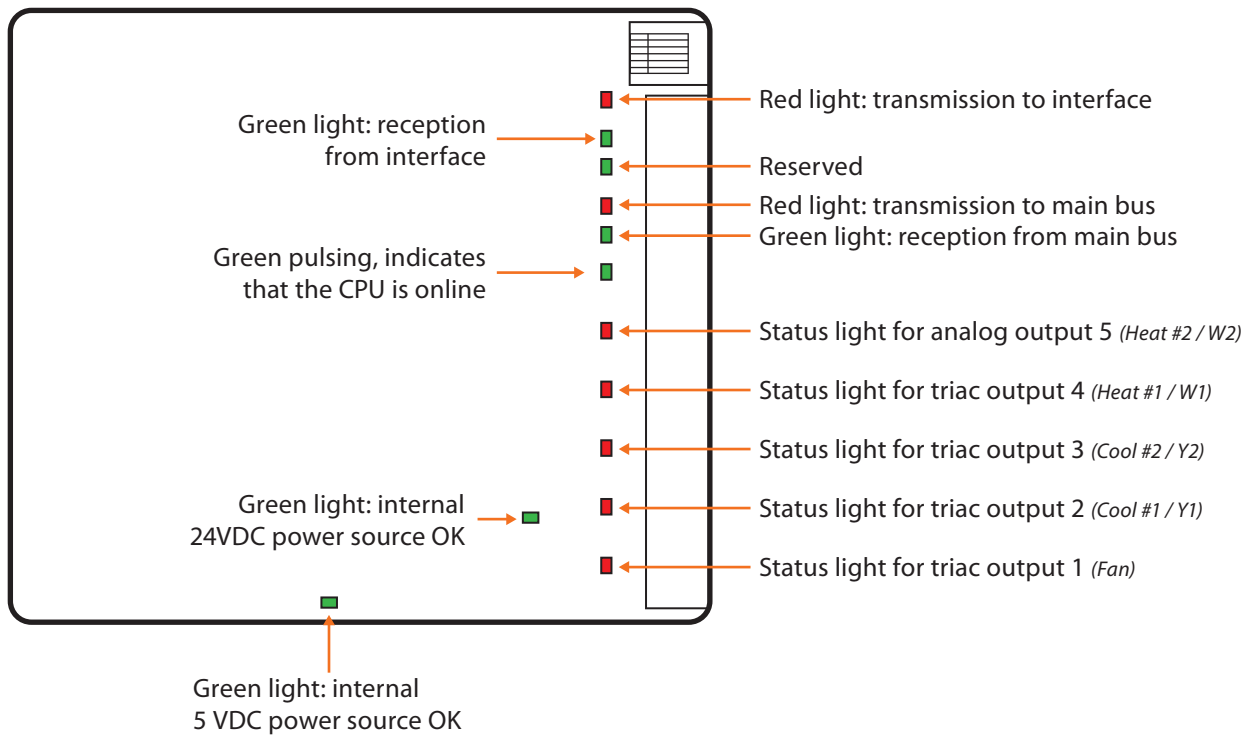

Figure 2 - LEDs Identification

Addressing DIP switch Configuration for Network Communication

A unique address must be configured on each controller by setting the first 7 switches on the addressing DIP switch to the desired value.

These switches are numbered from 1 to 7 and represent a binary value from 1 to 64 (1, 2, 4, 8, 16, 32, and 64 respectively). The last switch (#8) is reserved. The value of each switch that is in the ON position is added together to form the numerical address of the controller.

The example in Figure 3 shows the switches 1, 2 and 4 in the ON position. Therefore, the corresponding values are 1, 2 and 8, giving an address sum of 11.

The Proton network allows a maximum of 127 addresses, therefore 127 controllers.

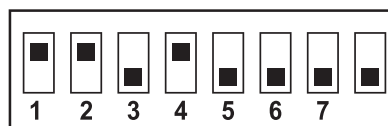

Figure 3 - Addressing DIP switches



Jumper to Supply Power to the RJ45 Plug

The RJ45 jumper lets the user select if voltage that will appear on pin #7 of the RJ45 plug. This can be used to power a device attached to the RJ45 plug, such as a digital sensor or interface.

Note: If multiple C1000 controllers are connected together through the RJ45 plug, **only one** C1000 should be supplying power onto the RJ45, otherwise you will be mixing your supply sources and possibly cause damage. The jumper setups are as follows:



Figure 4 - RJ45 Jumper

Input and Output Identification

All the inputs and outputs of the C1000 use pluggable screw type terminal blocks with elevator style clamping, which make connections easier and more secure.

For incoming communication from a remote computer or network controller, an RJ45 type connector is available. The RJ45 connector allows the use of premade CAT5 cables for simple plug-and-play RS485 communication. This RJ45 connector follows the Modbus pinout specification for RS485 communication.

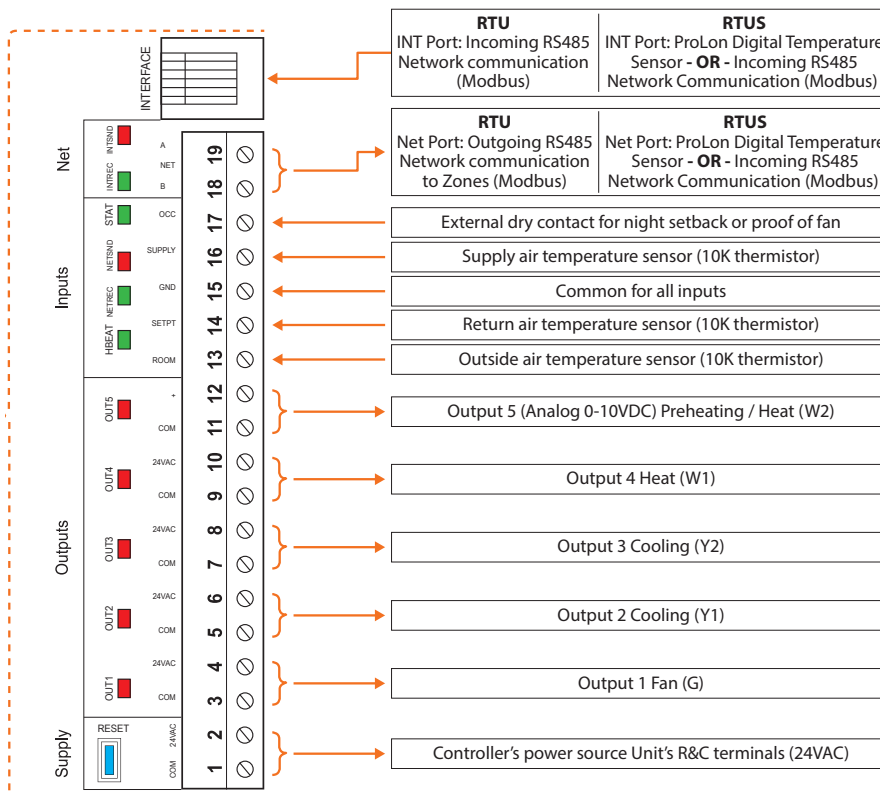

Figure 5 - Input and Output Identification

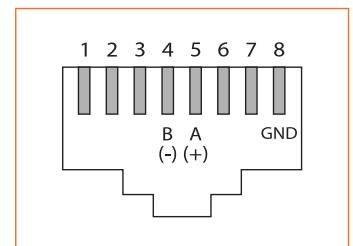

Figure 6 - RJ45 Pinout



Temperature Sensors

The C1000 Rooftop controller has three analog inputs that monitor outside air, return air and supply air temperatures (see Figure 7) and will integrate these readings into its control sequence. The sensors used are standard 10k type 3 thermistors that share a single common connection.

Alternatively, the supply air temperature can be retrieved from a zone controller that has its own supply sensor and belongs to the C1000's network.

The outside air temperature can be also be provided by an alternate source. If a network controller is present on the network, it can retrieve the outside temperature reading from one controller and distribute it to any other controllers on the network.

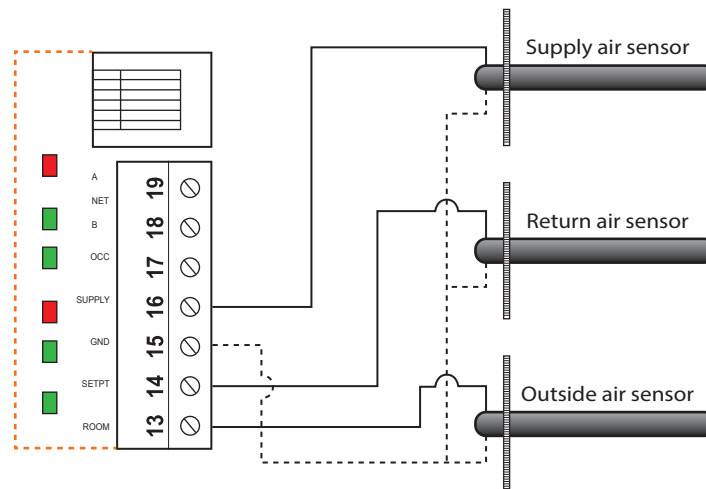

Figure 7 - Connecting the Sensors



Occupancy Mode (Night Setback)

Temperature setback savings can be obtained by using a dry contact originating from an external timer to switch the controller from occupied to unoccupied mode. The timer contact used must be connected to the "OCC" and the "GND" terminals (see Figure 8). To indicate occupied mode, the contact must be open. To indicate unoccupied mode, the contact must be closed. As a network Master, the Rooftop controller will then send the occupancy status to all known slaves on his network.

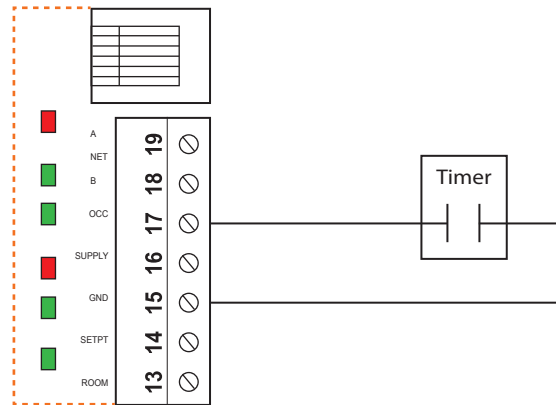

Figure 8 - Night Setback Contact Connection

Proof of Fan

The C1000 has a digital input that can be used to receive the proof of fan signal. Please refer to Figure 9 to see how to correctly connect it. To indicate proof of fan, the contact must be closed.

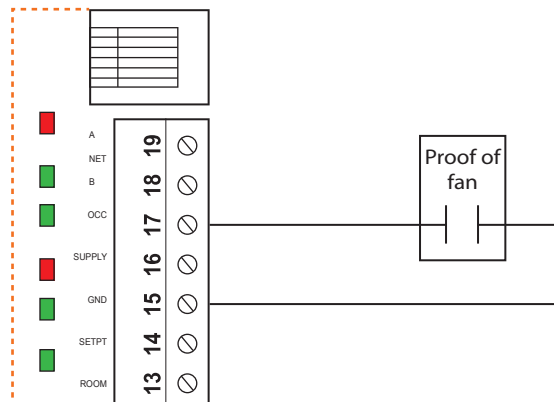

Figure 9 - Connecting the Proof of Fan Contact to the Controller



Outputs

The C1000 Basic Rooftop controller contains 5 customizable outputs, 4 being Triac type switch outputs and one being 0-10Vdc analog modulating / pulsed / On-or-Off output. Some outputs are configurable and follow a proportional and integral algorithm (PI) to ensure precise adjustment of the device. All configurations are performed via the Prolon Focus software.

An integrated resettable fuse protects each of the outputs of the C1000 against current surges and short circuits. This protection will cut the current to the output as soon as an overload condition is detected. The fuse is a round, yellow-coloured PTC that will change to orange and heat up on an overload condition. Once power has been removed from the C1000, the fuse will cool down and automatically reset. Fix the faulty wiring and you will be able to activate the output once again.

Output Specifications

Output	Type	Action	Application
1	Triac source 24VAC, Max Current: 300 mA	On-or-Off	Fan
2	Triac source 24VAC, Max Current: 300 mA	On-or-Off	Cooling (1st Stage)
3	Triac source 24VAC, Max Current: 300 mA	On-or-Off	Cooling (2nd Stage)
4	Triac source 24VAC, Max Current: 300 mA	On-or-Off	Heating (1st or 2nd Stage) / Preheat Permission
5	Configurable Analog Output: - 0 to 10 VDC - 2 to 10 VDC - 0 to 5 VDC Max Current: 40 mA	Modulating Proportional / Pulse / On-or-Off	Preheating only / Preheat + Heating / Heating (1st or 2nd Stage)



Typical Connection of the Triac Outputs 1 through 4

On the C1000 Rooftop controller, all triac outputs must be set to SOURCE mode because they all share a single source supply: the equipment's transformer. All triac outputs have a SOURCE / SINK configuration switch; they must be set to "SWITCH" (move switch towards terminal blocks). Only the terminal blocks marked 24 VAC are used for each output (see Figure 10).

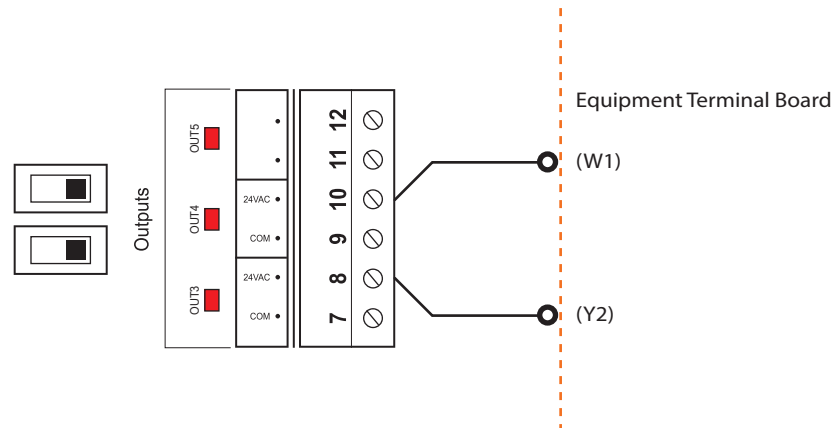

Figure 10 - Connection of Outputs 3 and 4

Typical Connection of Output #5

Output 5 is an analog output 0-10 VDC. It can be configured to modulate a 0 to 10 VDC load, to pulse a 0 or 10 VDC Triac relay or to control a 10 VDC On/Off relay (see Figure 11).

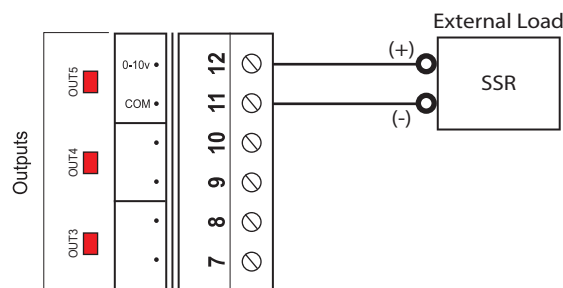

Figure 11 - Connecting the Analog Output (External Power)



PTA2 Connection on Output 2 for Analog Cooling

When analog cooling is required, the C1000 Rooftop controller must be equipped with a PTA2 v.1. The PTA2 input is connected to Output 2 on the C1000 Rooftop controller. The input pulse range must be set to 0.1-10 sec. For more information on the PTA2, consult the Specification Sheet and the Installation Guide for the PTA2.

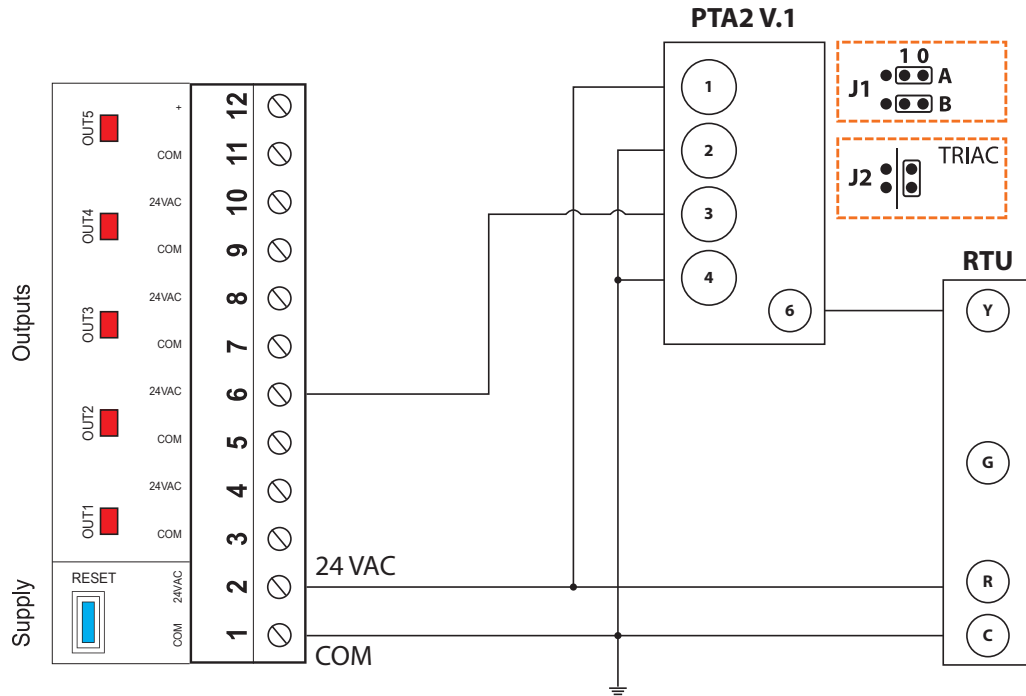

Figure 13 - Connecting the PTA2 (Powered by C1000)



Power Source & Network

Power Source

The C1000 controller is powered by the HVAC equipment's 24 VAC power supply by connecting the common ("C" wire) to the "COM" terminal block and the live ("R" wire) to the "24 VAC" terminal block (see Figure 14). The common for all inputs and outputs is the same as the power source's common. All output power sources also originate from the controller's power source.

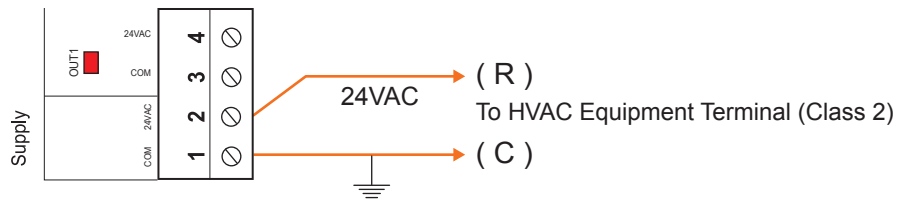

Figure 14 - Connecting the 24VAC Power Source

Network Communication

The Proton C1000 Rooftop controller is primarily designed to work with Proton zone controllers. When they are networked the Rooftop and zone controllers all communicate in real-time. The network connections are made using the network terminal blocks located on the C1000 controller (see Figure 15).

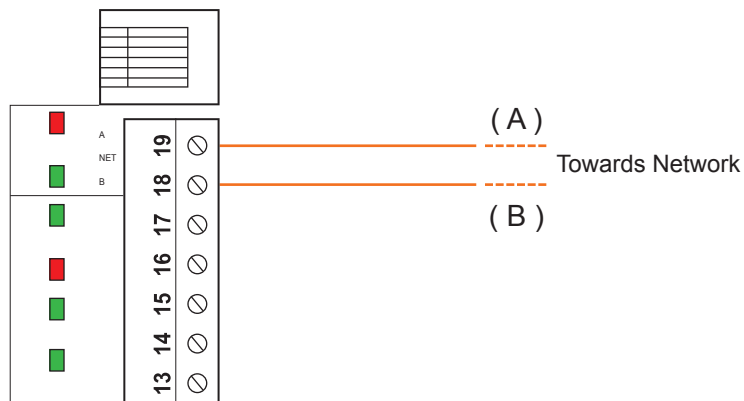

Figure 15 - Connecting to the Network



Technical Specifications

Supply: 24 VAC \pm 10%, 50/60 Hz, Class 2

Consumption: 2 VA (Consumption), 32 VA (Input)

Inputs:

- Outdoor – thermistor 10K
- Return – thermistor 10K
- Supply – thermistor 10K
- External clock or Proof of fan– dry contact

Digital outputs: 4 triac outputs, 10-30 VAC source or sink, 300 mA max (resettable fuse)

Analog output: 1 output 0-10 VDC / 2-10 VDC / 0-5 VDC, 40 mA max (resettable fuse)

Indication lights (LED): State of each output / Communication / Power / State of microprocessor

Microprocessor: PIC18F6722, 8 bits, 40 MHz, 128KB FLASH memory

Casing: Molded ABS, UL94-HB

Communication: Modbus RTU (RS485), up to 127 nodes

Baud rate: 9600, 19200, 38400, 57600, 76800, 115200

Connection: Removable screw-type terminal blocks (16 AWG max) and RJ45 modular jack

Dimensions: 6.2" x 5.2" x 2.5" (157 mm x 132 mm x 64 mm)

Weight: 0.85 lbs (0.39 kg)

Environment: 32-122 °F (0-50 °C) Non-Condensing

Certification: UL916 Energy Management Equipment, CAN/CSA-C22.2, RoHS, FCC part 15: 2012 class B

The performance specifications are nominal and conform to acceptable industry standards. Prolon Inc. will not be liable for damages resulting from misapplication or misuse of its products.



Compliance

- FCC Compliant to CFR47, Part 15, Subpart B, Class B
- Industry Canada (IC) Compliant to ICES-003, Issue 5: CAN ICES-3 (B)/NMB-3(B)
- RoHS Directive (2002/95/EC)

FCC User Information

This device complies with Part 15 of the FCC Rules. Operation is subject to the following two conditions: (1) this device may not cause harmful interference, and (2) this device must accept any interference received, including interference that may cause undesired operation.

Caution: Any changes or modifications not approved by Proton can void the user's authority to operate the equipment.

Note: This equipment has been tested and found to comply with the limits for a Class B digital device, pursuant to part 15 of the FCC Rules. These limits are designed to provide reasonable protection against harmful interference in a residential installation. This equipment generates, uses and can radiate radio frequency energy and, if not installed and used in accordance with the instructions, may cause harmful interference to radio communications. However, there is no guarantee that interference will not occur in a particular installation. If this equipment does cause harmful interference to radio or television reception, which can be determined by turning the equipment off and on, the user is encouraged to try to correct the interference by one or more of the following measures:

- Reorient or relocate the receiving antenna.
- Increase the separation between the equipment and receiver.
- Connect the equipment into an outlet on a circuit different from that to which the receiver is connected.
- Consult the dealer or an experienced radio/TV technician for help.

Industry Canada

This Class (B) digital apparatus meets all the requirements of the Canadian Interference-Causing Equipment regulations.

Cet appareil numérique de la Classe (B) respecte toutes les exigences du Règlement sur le matériel brouilleur du Canada.



Overall Dimensions

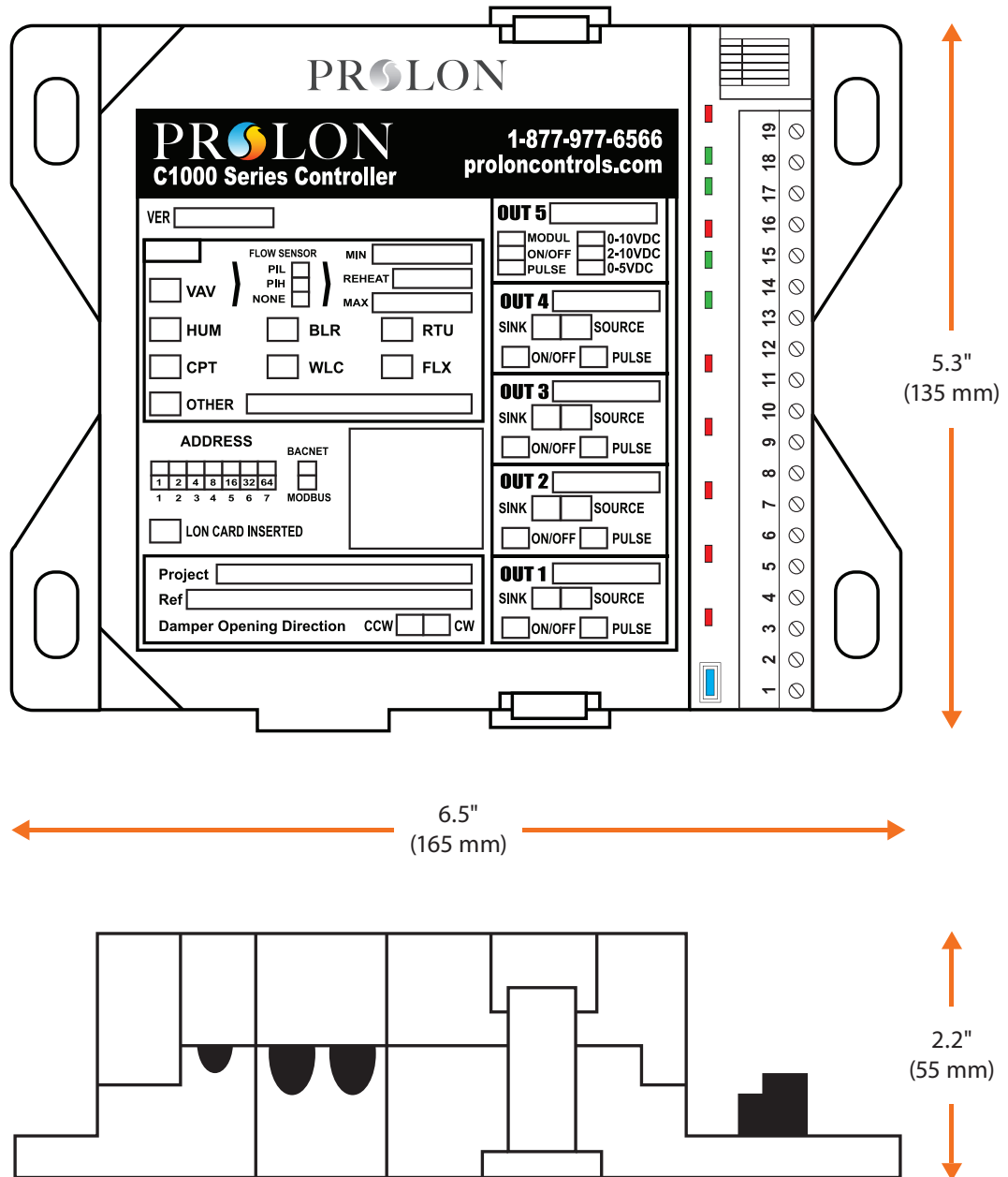

Figure 16 - C1000 Size Diagram

REV. 7.1.1

PL-HRDW-RTU-C1000-C/F-EN

© Copyright 2019 Prolon. All rights reserved.

No part of this document may be photocopied or reproduced by any means, or translated to another language without prior written consent of Prolon. All specifications are nominal and may change as design improvements are introduced. Prolon shall not be liable for damages resulting from misapplication or misuse of its products. All trademarks are the property of their respective owners.