

# PL-PN2-M2-FLX-M2-MUA

## Internal Electrical Wiring Diagram

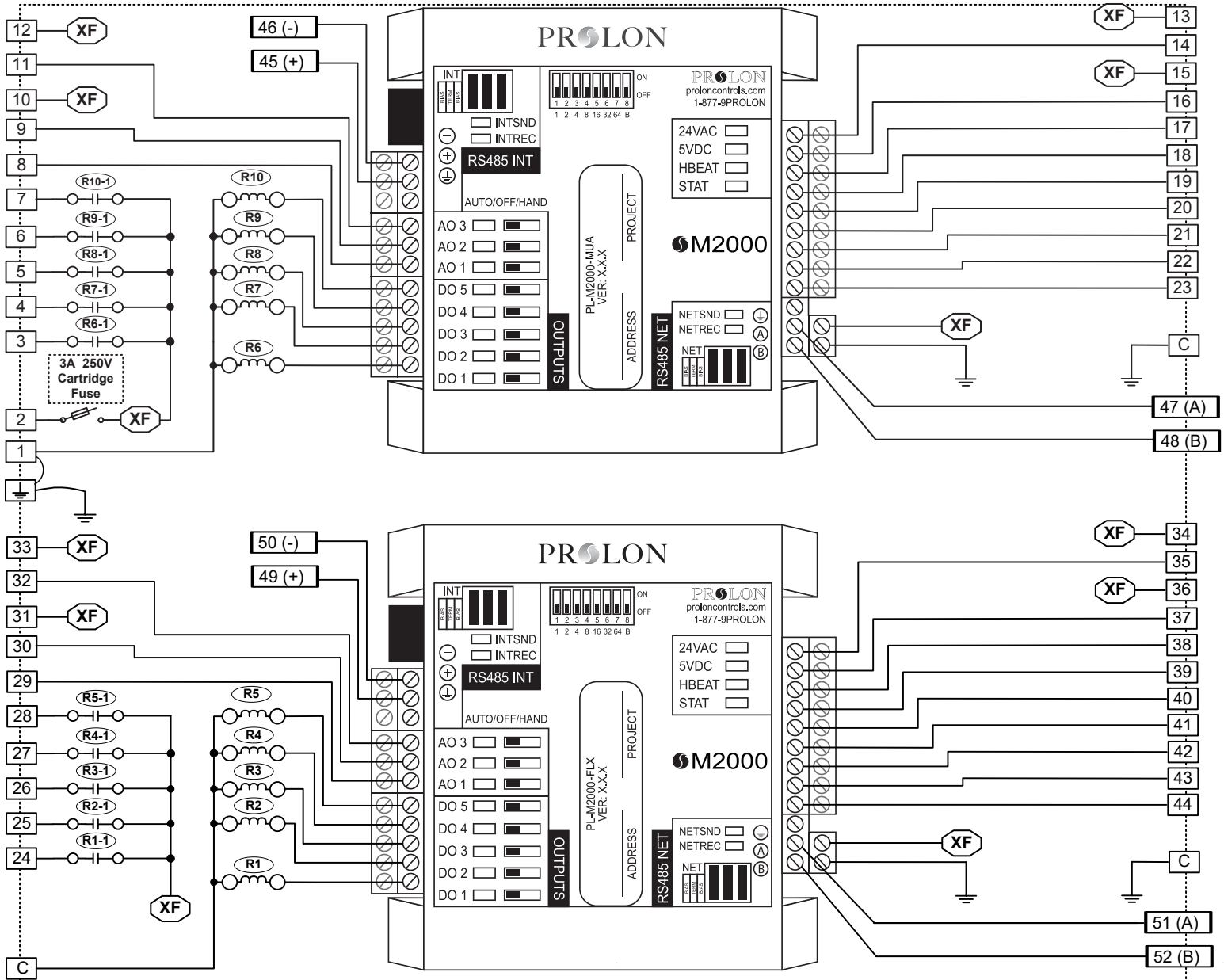

Terminal	Function	Ratings	Wiring Details
	GROUND	N/A	Use Copper Conductors Only, 105°C/220°F, Maximum Torque Conductor Mounting: 0.5Nm
1	Power Supply Input Common	N/A	Use Copper Conductors Only, 105°C/220°F, Maximum Torque Conductor Mounting: 0.5Nm
2	Power Supply Input 24 VAC	24 VAC, 3 A, 60Hz	Use Copper Conductors Only, 105°C/220°F, Maximum Torque Conductor Mounting: 0.5Nm
3	Occupancy Output	24 VAC, 160 mA	Use Copper Conductors Only, 105°C/220°F, Maximum Torque Conductor Mounting: 0.5Nm
4	Outside Air Damper Output	24 VAC, 160 mA	Use Copper Conductors Only, 105°C/220°F, Maximum Torque Conductor Mounting: 0.5Nm
5	Fan Output	24 VAC, 160 mA	Use Copper Conductors Only, 105°C/220°F, Maximum Torque Conductor Mounting: 0.5Nm
6	Preheat Permission Output	24 VAC, 160 mA	Use Copper Conductors Only, 105°C/220°F, Maximum Torque Conductor Mounting: 0.5Nm
7	Alarm Output	24 VAC, 160 mA	Use Copper Conductors Only, 105°C/220°F, Maximum Torque Conductor Mounting: 0.5Nm
8	Modulating Heat Output	0-10 VDC, 40 mA	Use Copper Conductors Only, 105°C/220°F, Maximum Torque Conductor Mounting: 0.5Nm
9	Cooling Output	0-10 VDC, 40 mA	Use Copper Conductors Only, 105°C/220°F, Maximum Torque Conductor Mounting: 0.5Nm
10	24 VAC Supply	24 VAC, 8.5 VA	Use Copper Conductors Only, 105°C/220°F, Maximum Torque Conductor Mounting: 0.5Nm
11	VFD Output	0-10 VDC, 40 mA	Use Copper Conductors Only, 105°C/220°F, Maximum Torque Conductor Mounting: 0.5Nm
12	VFD Supply	24 VAC, 5 VA	Use Copper Conductors Only, 105°C/220°F, Maximum Torque Conductor Mounting: 0.5Nm
13	Static Pressure Sensor Supply	24 VAC, 0.03 A	Use Copper Conductors Only, 105°C/220°F, Maximum Torque Conductor Mounting: 0.5Nm
14	CO2 / Building Pressure	0-5 VDC, 20 mA	Use Copper Conductors Only, 105°C/220°F, Maximum Torque Conductor Mounting: 0.5Nm
15	CO2 Sensor Supply	24 VAC, 6.7 VA	Use Copper Conductors Only, 105°C/220°F, Maximum Torque Conductor Mounting: 0.5Nm
16	Zone Temperature	N/A	Use Copper Conductors Only, 105°C/220°F, Maximum Torque Conductor Mounting: 0.5Nm
17	Outside Temperature	N/A	Use Copper Conductors Only, 105°C/220°F, Maximum Torque Conductor Mounting: 0.5Nm
18	Supply Temperature	N/A	Use Copper Conductors Only, 105°C/220°F, Maximum Torque Conductor Mounting: 0.5Nm
19	Dry Contact for: Manual Reset	N/A	Use Copper Conductors Only, 105°C/220°F, Maximum Torque Conductor Mounting: 0.5Nm
20	Dry Contact for: Proof of Fan	N/A	Use Copper Conductors Only, 105°C/220°F, Maximum Torque Conductor Mounting: 0.5Nm
21	Dry Contact for: Outside Air Damper	N/A	Use Copper Conductors Only, 105°C/220°F, Maximum Torque Conductor Mounting: 0.5Nm
22	Dry Contact for: Exhaust 2 / Manual override	N/A	Use Copper Conductors Only, 105°C/220°F, Maximum Torque Conductor Mounting: 0.5Nm
23	Dry Contact for: Exhaust 1	N/A	Use Copper Conductors Only, 105°C/220°F, Maximum Torque Conductor Mounting: 0.5Nm
45 (+)	M2000 RS485 INT A (+)	N/A	Use Copper Conductors Only, 105°C/220°F, Maximum Torque Conductor Mounting: 0.5Nm
46 (-)	M2000 RS485 INT B (-)	N/A	Use Copper Conductors Only, 105°C/220°F, Maximum Torque Conductor Mounting: 0.5Nm
47 (A)	M2000 RS485 NET A (+)	N/A	Use Copper Conductors Only, 105°C/220°F, Maximum Torque Conductor Mounting: 0.5Nm

Terminal	Function	Ratings	Wiring Details
48 (B)	M2000 RS485 NET B (-)	N/A	Use Copper Conductors Only, 105°C/220°F, Maximum Torque Conductor Mounting: 0.5Nm
24	Digital Output 1	24 VAC, 160mA	Use Copper Conductors Only, 105°C/220°F, Maximum Torque Conductor Mounting: 0.5Nm
25	Digital Output 2	24 VAC, 160mA	Use Copper Conductors Only, 105°C/220°F, Maximum Torque Conductor Mounting: 0.5Nm
26	Digital Output 3	24 VAC, 160mA	Use Copper Conductors Only, 105°C/220°F, Maximum Torque Conductor Mounting: 0.5Nm
27	Digital Output 4	24 VAC, 160 mA	Use Copper Conductors Only, 105°C/220°F, Maximum Torque Conductor Mounting: 0.5Nm
28	Digital Output 5	24 VAC, 160mA	Use Copper Conductors Only, 105°C/220°F, Maximum Torque Conductor Mounting: 0.5Nm
29	Analog Output 1	0-10VDC, 40mA	Use Copper Conductors Only, 105°C/220°F, Maximum Torque Conductor Mounting: 0.5Nm
30	Analog Output 2	0-10VDC, 40mA	Use Copper Conductors Only, 105°C/220°F, Maximum Torque Conductor Mounting: 0.5Nm
31	Power Supply 24VAC	24 VAC, 40mA	Use Copper Conductors Only, 105°C/220°F, Maximum Torque Conductor Mounting: 0.5Nm
32	Analog Output 3	0-10VDC, 40mA	Use Copper Conductors Only, 105°C/220°F, Maximum Torque Conductor Mounting: 0.5Nm
33	Power Supply 24VAC	24 VAC, 40mA	Use Copper Conductors Only, 105°C/220°F, Maximum Torque Conductor Mounting: 0.5Nm
34	Power Supply 24VAC	24 VAC, 40mA	Use Copper Conductors Only, 105°C/220°F, Maximum Torque Conductor Mounting: 0.5Nm
35	Analog Input 9	5 VDC, 20 mA	Use Copper Conductors Only, 105°C/220°F, Maximum Torque Conductor Mounting: 0.5Nm
36	Power Supply 24VAC	24 VAC, 40mA	Use Copper Conductors Only, 105°C/220°F, Maximum Torque Conductor Mounting: 0.5Nm
37	Analog Input 8	5 VDC, 20 mA	Use Copper Conductors Only, 105°C/220°F, Maximum Torque Conductor Mounting: 0.5Nm
38	Analog Input 7	5 VDC, 20 mA	Use Copper Conductors Only, 105°C/220°F, Maximum Torque Conductor Mounting: 0.5Nm
39	Analog Input 6	5 VDC, 20 mA	Use Copper Conductors Only, 105°C/220°F, Maximum Torque Conductor Mounting: 0.5Nm
40	Analog Input 5	5 VDC, 20 mA	Use Copper Conductors Only, 105°C/220°F, Maximum Torque Conductor Mounting: 0.5Nm
41	Analog Input 4	5 VDC, 20 mA	Use Copper Conductors Only, 105°C/220°F, Maximum Torque Conductor Mounting: 0.5Nm
42	Analog Input 3	5 VDC, 20 mA	Use Copper Conductors Only, 105°C/220°F, Maximum Torque Conductor Mounting: 0.5Nm
43	Analog Input 2	5 VDC, 20 mA	Use Copper Conductors Only, 105°C/220°F, Maximum Torque Conductor Mounting: 0.5Nm
44	Analog Input 1	5 VDC, 20 mA	Use Copper Conductors Only, 105°C/220°F, Maximum Torque Conductor Mounting: 0.5Nm
49 (+)	M2000 RS485 INT A (+)	N/A	Use Copper Conductors Only, 105°C/220°F, Maximum Torque Conductor Mounting: 0.5Nm
50 (-)	M2000 RS485 INT B (-)	N/A	Use Copper Conductors Only, 105°C/220°F, Maximum Torque Conductor Mounting: 0.5Nm
51 (A)	M2000 RS485 NET A (+)	N/A	Use Copper Conductors Only, 105°C/220°F, Maximum Torque Conductor Mounting: 0.5Nm
52 (B)	M2000 RS485 NET B (-)	N/A	Use Copper Conductors Only, 105°C/220°F, Maximum Torque Conductor Mounting: 0.5Nm
C	COMMON	N/A	Use Copper Conductors Only, 105°C/220°F, Maximum Torque Conductor Mounting: 0.5Nm