

# PL-PN2-M2-RTU-M2-BLR

## Internal Electrical Wiring Diagram

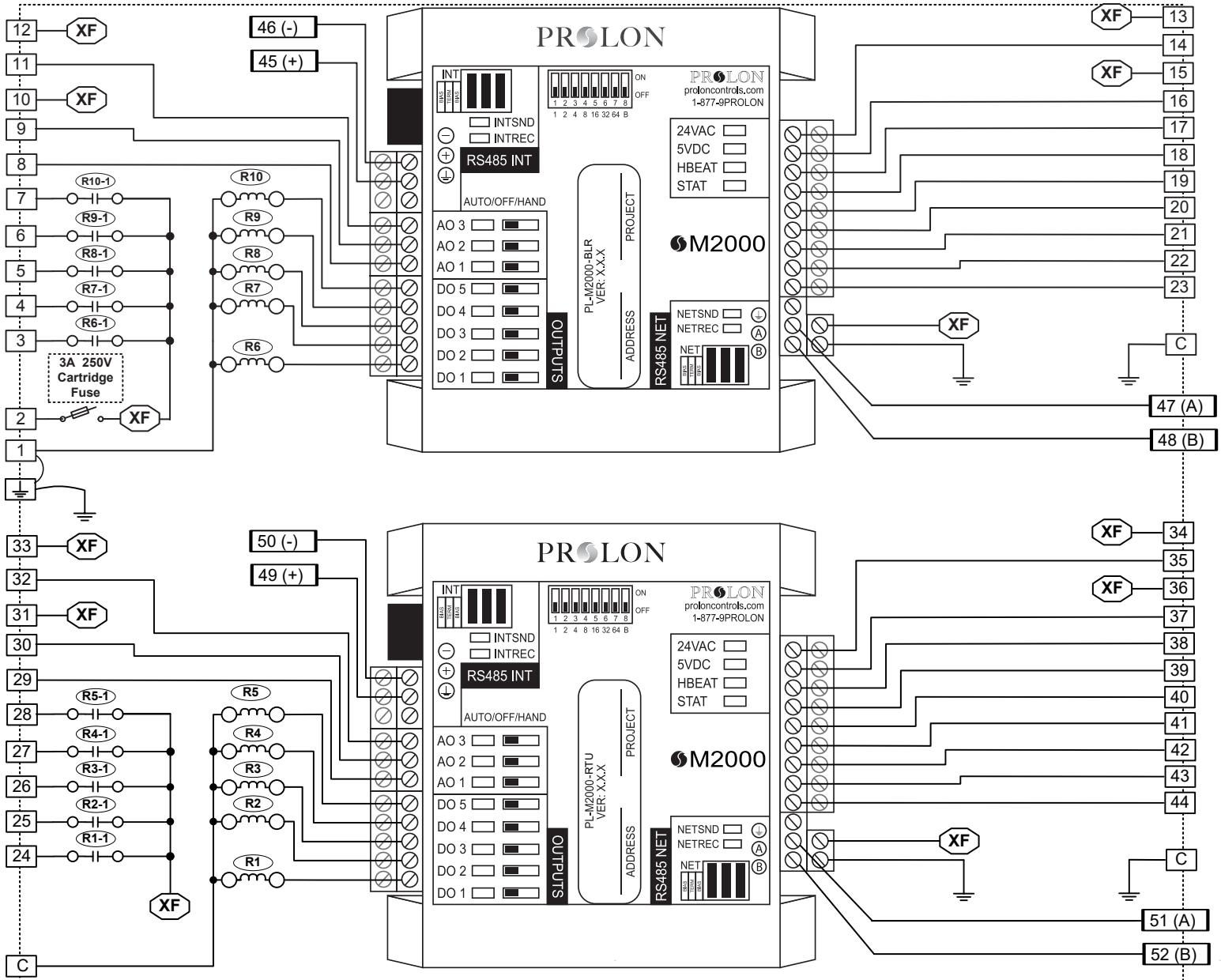

Terminal	Function	Rating	Wiring Details
	GROUND	N/A	Use Copper Conductors Only, 105°C/220°F, Maximum Torque Conductor Mounting: 0.5 m
1	Power Supply Input Common	N/A	Use Copper Conductors Only, 105°C/220°F, Maximum Torque Conductor Mounting: 0.5 m
2	Power Supply Input 24 VAC	24 VAC, 3 A, 60Hz	Use Copper Conductors Only, 105°C/220°F, Maximum Torque Conductor Mounting: 0.5 m
3	Boiler Stage 1 Output	24 VAC, 160 mA	Use Copper Conductors Only, 105°C/220°F, Maximum Torque Conductor Mounting: 0.5 m
4	Boiler Stage 2 Output	24 VAC, 160 mA	Use Copper Conductors Only, 105°C/220°F, Maximum Torque Conductor Mounting: 0.5 m
5	Boiler Stage 3 Output	24 VAC, 160 mA	Use Copper Conductors Only, 105°C/220°F, Maximum Torque Conductor Mounting: 0.5 m
6	Boiler Stage 4 Output	24 VAC, 160 mA	Use Copper Conductors Only, 105°C/220°F, Maximum Torque Conductor Mounting: 0.5 m
7	Pump 1 Output	24 VAC, 160 mA	Use Copper Conductors Only, 105°C/220°F, Maximum Torque Conductor Mounting: 0.5 m
8	Pump 2 Output	0-10 VDC, 40 mA	Use Copper Conductors Only, 105°C/220°F, Maximum Torque Conductor Mounting: 0.5 m
9	Modulating Boiler Output	0-10 VDC, 40 mA	Use Copper Conductors Only, 105°C/220°F, Maximum Torque Conductor Mounting: 0.5 m
10	24 VAC Supply	24 VAC, 40mA	Use Copper Conductors Only, 105°C/220°F, Maximum Torque Conductor Mounting: 0.5 m
11	Valve or Backup Modulating Boiler	0-10 VDC, 40mA	Use Copper Conductors Only, 105°C/220°F, Maximum Torque Conductor Mounting: 0.5 m
12	24 VAC Supply	24 VAC, 40mA	Use Copper Conductors Only, 105°C/220°F, Maximum Torque Conductor Mounting: 0.5 m
13	24 VAC supply	24 VAC, 40mA	Use Copper Conductors Only, 105°C/220°F, Maximum Torque Conductor Mounting: 0.5 m
14	N/A	N/A	N/A
15	24 VAC Supply	24 VAC, 40mA	Use Copper Conductors Only, 105°C/220°F, Maximum Torque Conductor Mounting: 0.5 m
16	N/A	N/A	N/A
17	Dry Contact to Disable Boiler Call	N/A	Use Copper Conductors Only, 105°C/220°F, Maximum Torque Conductor Mounting: 0.5 m
18	Dry Contact for Max Heat Setpoint	N/A	Use Copper Conductors Only, 105°C/220°F, Maximum Torque Conductor Mounting: 0.5 m
19	Dry Contact for Proof of Pump 2	N/A	Use Copper Conductors Only, 105°C/220°F, Maximum Torque Conductor Mounting: 0.5 m
20	Dry Contact for Proof of Pump 1	N/A	Use Copper Conductors Only, 105°C/220°F, Maximum Torque Conductor Mounting: 0.5 m
21	Return Water Temperature Thermistor (10K Type 3)	N/A	Use Copper Conductors Only, 105°C/220°F, Maximum Torque Conductor Mounting: 0.5 m
22	Supply Water Temperature Thermistor (10K Type 3)	N/A	Use Copper Conductors Only, 105°C/220°F, Maximum Torque Conductor Mounting: 0.5 m
23	Outside Air Temperature Thermistor (10K Type 3)	N/A	Use Copper Conductors Only, 105°C/220°F, Maximum Torque Conductor Mounting: 0.5 m
45 (+)	M2000 RS485 INT A (+)	N/A	Use Copper Conductors Only, 105°C/220°F, Maximum Torque Conductor Mounting: 0.5 m
46 (-)	M2000 RS485 INT B (-)	N/A	Use Copper Conductors Only, 105°C/220°F, Maximum Torque Conductor Mounting: 0.5 m
47 (A)	M2000 RS485 NET A (+)	N/A	Use Copper Conductors Only, 105°C/220°F, Maximum Torque Conductor Mounting: 0.5 m

Terminal	Function	Rating	Wiring Details
48 (B)	M2000 RS485 NET B (-)	N/A	Use Copper Conductors Only, 105°C/220°F, Maximum Torque Conductor Mounting: 0.5 m
24	Fan Output (G)	24 VAC, 300 mA	Use Copper Conductors Only, 105°C/220°F, Maximum Torque Conductor Mounting: 0.5 m
25	Cooling Output 1 (Y1)	24 VAC, 300 mA	Use Copper Conductors Only, 105°C/220°F, Maximum Torque Conductor Mounting: 0.5 m
26	Cooling Output 2 (Y2)	24 VAC, 300 mA	Use Copper Conductors Only, 105°C/220°F, Maximum Torque Conductor Mounting: 0.5 m
27	Heating Output 1 (W1)	24 VAC, 300 mA	Use Copper Conductors Only, 105°C/220°F, Maximum Torque Conductor Mounting: 0.5 m
28	Heating Output 2 (W2) or Exhaust Fan	24 VAC, 300 mA	Use Copper Conductors Only, 105°C/220°F, Maximum Torque Conductor Mounting: 0.5 m
29	Modulating Heating Output	0-10VDC, 40 mA	Use Copper Conductors Only, 105°C/220°F, Maximum Torque Conductor Mounting: 0.5 m
30	Economizer Control Output	0-10VDC, 40 mA	Use Copper Conductors Only, 105°C/220°F, Maximum Torque Conductor Mounting: 0.5 m
31	Economizer Supply	24 VAC, 8.5 VA	Use Copper Conductors Only, 105°C/220°F, Maximum Torque Conductor Mounting: 0.5 m
32	Bypass or VFD Control Output	0-10VDC, 40mA	Use Copper Conductors Only, 105°C/220°F, Maximum Torque Conductor Mounting: 0.5 m
33	Bypass or VFD Supply	24 VAC, 5 VA	Use Copper Conductors Only, 105°C/220°F, Maximum Torque Conductor Mounting: 0.5 m
34	Static Pressure Sensor Supply	24 VAC, 0.03 A	Use Copper Conductors Only, 105°C/220°F, Maximum Torque Conductor Mounting: 0.5 m
35	Static Pressure Sensor Input Signal	0-5 VDC, 5 uA	Use Copper Conductors Only, 105°C/220°F, Maximum Torque Conductor Mounting: 0.5 m
36	CO2 Sensor Supply	24 VAC, 6.7 VA	Use Copper Conductors Only, 105°C/220°F, Maximum Torque Conductor Mounting: 0.5 m
37	CO2 Sensor Input Signal	4-20 mA, 1-5VDC	Use Copper Conductors Only, 105°C/220°F, Maximum Torque Conductor Mounting: 0.5 m
38	Dry Contact for Proof of Fan	N/A	Use Copper Conductors Only, 105°C/220°F, Maximum Torque Conductor Mounting: 0.5 m
39	Zone Setpoint Potentiometer (0-9K)	N/A	Use Copper Conductors Only, 105°C/220°F, Maximum Torque Conductor Mounting: 0.5 m
40	Zone Temperature Thermistor (10K Type 3) Variable Function	N/A	Use Copper Conductors Only, 105°C/220°F, Maximum Torque Conductor Mounting: 0.5 m
41	Temperature Sensor	N/A	Use Copper Conductors Only, 105°C/220°F, Maximum Torque Conductor Mounting: 0.5 m
42	Supply Air Temperature Thermistor (10K Type 3)	N/A	Use Copper Conductors Only, 105°C/220°F, Maximum Torque Conductor Mounting: 0.5 m
43	Return Air Temperature Thermistor (10K Type 3)	N/A	Use Copper Conductors Only, 105°C/220°F, Maximum Torque Conductor Mounting: 0.5 m
44	Outside Air Temperature Thermistor (10K Type 3)	N/A	Use Copper Conductors Only, 105°C/220°F, Maximum Torque Conductor Mounting: 0.5 m
49 (+)	M2000 RS485 INT A (+)	N/A	Use Copper Conductors Only, 105°C/220°F, Maximum Torque Conductor Mounting: 0.5 m
50 (-)	M2000 RS485 INT B (-)	N/A	Use Copper Conductors Only, 105°C/220°F, Maximum Torque Conductor Mounting: 0.5 m
51 (A)	M2000 RS485 NET A (+)	N/A	Use Copper Conductors Only, 105°C/220°F, Maximum Torque Conductor Mounting: 0.5 m
52 (B)	M2000 RS485 NET B (-)	N/A	Use Copper Conductors Only, 105°C/220°F, Maximum Torque Conductor Mounting: 0.5 m
C	COMMON	N/A	Use Copper Conductors Only, 105°C/220°F, Maximum Torque Conductor Mounting: 0.5 m