

Prolon Controls

Boiler Applications



All-in-one Controller: Keeping it Simple

The PL-M2000-BLR effectively controls ALL components of a light commercial boiler system. Whether it be multiple boilers, multiple pumps, pump status, valves and/or sensors, it all connects to a single controller! Every input and output is preset out of the box, allowing for true plug-and-play operation.



Standalone or Networked: Always Ready

The PL-M2000-BLR controller can work as either a standalone controller or can be networked into a communicating system. It's your choice!



Configure in a Matter of Minutes: Save Time and Money

The PL-M2000-BLR is a highly configurable controller, combining schedules, pump control, boiler control, and loop temperature reset; all accessible from a single access point. View and configure your entire system in real time with animated graphics, using either the free Prolon Focus Software or the Focus Mobile App (for Android and iOS devices).



Remote Access and Email Alerts: Keeping an Eye on Your System

When combined with Prolon's Network Controller, feel the power of true connectivity as you can access the PL-M2000-BLR controller remotely to monitor and configure any parameter. Want to receive notifications? Configuring email alerts is a breeze; it will take less than 5 minutes, guaranteed!

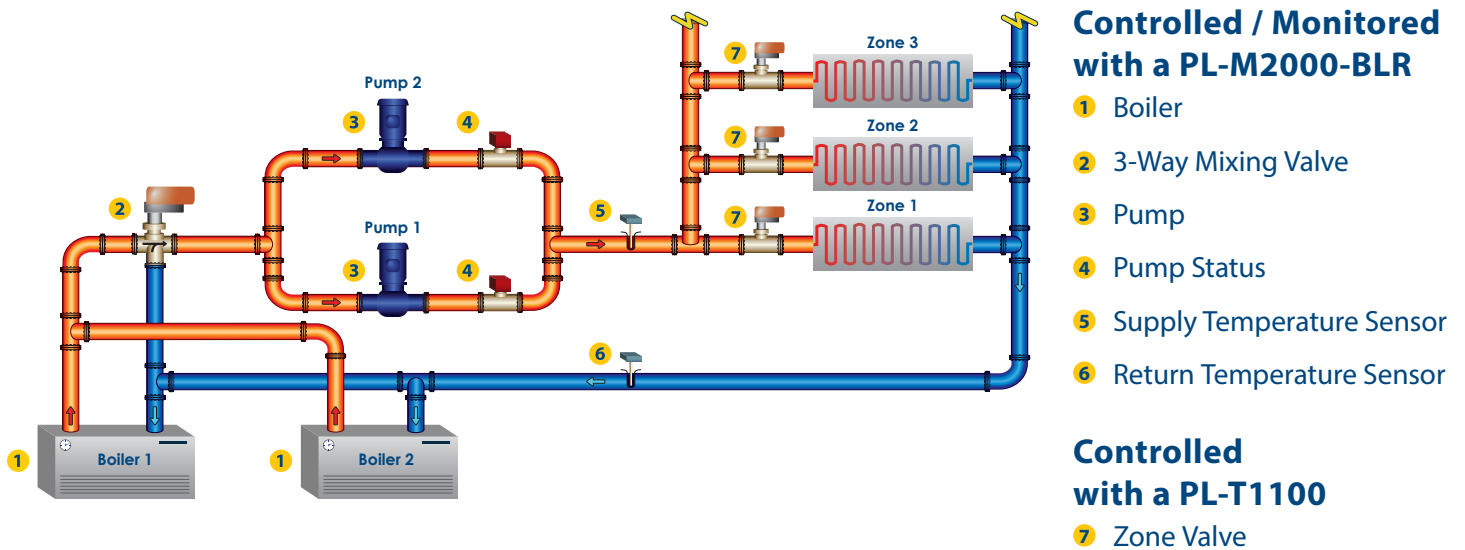

Prolon Controls

Boiler Hardware Features



PL-M2000-BLR Boiler Controller

- Control 1 or 2 pumps, complete with lead/lag and equal runtime sequences
- Control up to 4 boiler stages, or a modulating boiler + backup boiler
- Boiler stages also have lead/lag and equal runtime sequences
- Add a mixing 3-way valve for increased control
- Fixed temperature setpoint – OR – Reset temperature setpoint based on Outside Air Temperature
- Pump exercise sequence for periods of inactivity
- Unoccupied mode for energy savings
- Configurable schedules and calendars
- Manual/Off/Auto switches for each output



PL-T1100 Digital Thermostat

- Fully configurable digital (1x) and analog (1x) output
- Circular touchpad and graphical display
- Proportional integral (PI) control loop
- Additional input for zone temperature averaging

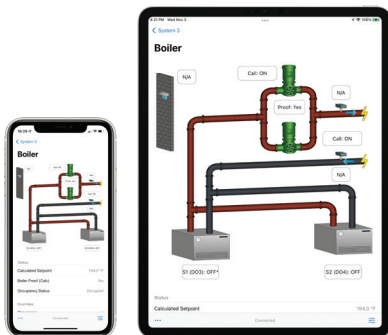

Monitor Your Boiler System Remotely Using Focus

Prolon's FREE Focus visualization software is now available as an app for both Apple and Android devices! Fully animated graphics and total configuration capabilities from your wireless device allow you the freedom to monitor your system anywhere, anytime. Say goodbye to unnecessary service calls and hello to proactive responses by adding email alerts for another layer of control. Complete power from the palm of your hand... **That's Prolon Focus!**