



HARDWARE GUIDE

FlexIO Controller C1050 Series

Specifications and Operational Guide

www.proloncontrols.com | info@proloncontrols.com
17 510, rue Charles, Suite 100, Mirabel, QC, J7J 1X9



Table of Contents

General Information	4
PL-C1050 FLX Controller	4
Description.....	4
Features.....	4
Components.....	5
Components Identification	5
LEDs	6
Address Configuration for Networking	6
Input and Output Identification.....	7
Inputs	8
Analog Input.....	8
Signal: Thermistor.....	8
Signal: Contact.....	9
Signal: Voltage	9
Signal: Current	10
Outputs	11
Output Specifications	11
Configuration of Digital Outputs.....	11
Typical Connection of Digital Outputs	12
Typical Connection of Analog Outputs	13
Power Source / Network	14
Power Source	14
Network Communication	14
Technical Specifications	15
Compliance	16
FCC User Information	16
Industry Canada	16
Overall Dimensions.....	17



Table of Figures

Figure 1 - Component Identification.....	5
Figure 2 - LEDs Identification	6
Figure 3 - Addressing Dipswitches.....	6
Figure 4 - Input and Output Identification.....	7
Figure 5 - Analog input	8
Figure 6 - Connecting a temperature sensor to analog input 1.....	8
Figure 7 - Connecting a dry contact to analog input 1	9
Figure 8 - Connecting voltage based sensors.....	9
Figure 9 - Connecting current based sensors	10
Figure 10 - Output in SOURCE mode	11
Figure 11 - Output in SINK mode.....	12
Figure 12 - Connection of active outputs 3 and 4	12
Figure 13 - Connection of passive outputs 3 and 4	12
Figure 14 - Connecting the analog output (controller powered)	13
Figure 15 - Connecting the analog output (external power)	13
Figure 16 - Connecting the 24VAC power source	14
Figure 17 - Connecting to the network.....	14
Figure 18 - C1050 Size Diagram.....	17



PL-C1050 FLX Controller

Description

The C1050 FlexIO is a general purpose HVAC controller whose inputs and outputs can be individually configured for use in various applications. Unlike most Prolon controllers, the FlexIO is not aimed at a specific HVAC sequence or piece of equipment, and instead can be used to perform any outlying functions that are not usually covered by existing Prolon devices. Outputs can be configured to respond to a variety of standard HVAC input signal types, ranging from temperatures, pressure, gas and more.

Features

- Many input types available: Temperature, Dry Contact, Pressure, Gas, Humidity
- Configurable names and display options for each input and output
- Configurable scales for pressure and gas inputs accommodates any sensor
- Outputs can act based on any local input, or on data received from a network master
- Can receive up to 5 different occupancy states from an NC2000, allowing for versatile lighting control
- Various output logic sequences are available: ON/OFF, PI Loop, Direct or Reverse acting, Pulsed
- Outputs can be interlocked with each other
- Outputs can be automatically overridden based on outside temperature and/or occupancy
- Operates standalone or can be integrated into a Prolon network





Components Identification

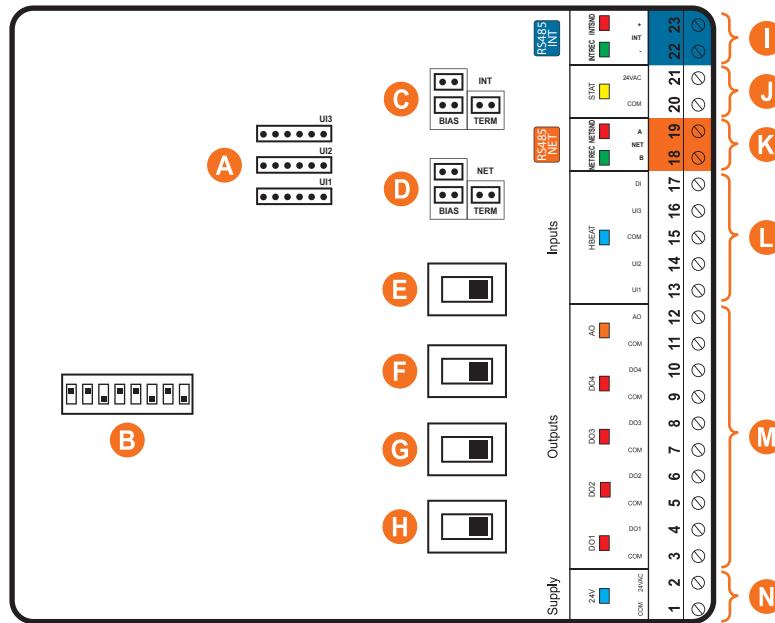

Figure 1 - Component Identification

Legend:

- A - Analog Input Signal Mode Jumpers
- B - Addressing dipswitch
- C - Jumpers for terminating and bias resistors for the INT port (see I)
- D - Jumpers for terminating and bias resistors for the NET port (see K)
- E - SOURCE/SINK dipswitch for Output 4
- F - SOURCE/SINK dipswitch for Output 3
- G - SOURCE/SINK dipswitch for Output 2
- H - SOURCE/SINK dipswitch for Output 1
- I - INT port for RS485 communication (terminal block)
- J - Alternate terminal blocks for 24 VAC (provides power to an optional digital sensor)
- K - NET port for RS485 communication (terminal block)
- L - Inputs (4 total)
- M - Terminal Blocks for Outputs 1 to 5
- N - Terminal Blocks for 24 VAC



LEDs

The C1050 has various LEDs which are linked to different functions and outputs of the controller. Each LED is individually identified to help the user make a quick visual diagnostic of the controller's activity and status.

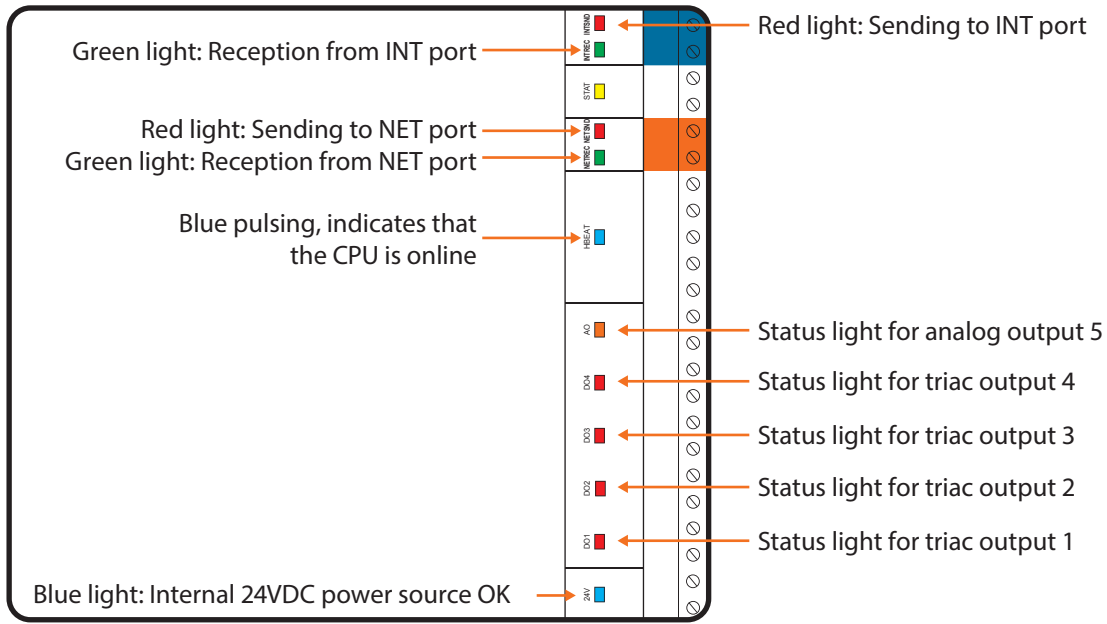

Figure 2 - LEDs Identification

Address Configuration for Networking

A unique address on each controller must be configured by setting the first 7 switches on the addressing dipswitch to the desired value.

These switches are numbered from 1 to 7 and represent a binary value from 1 to 64 (1, 2, 4, 8, 16, 32, 64 respectively). The value of each switch that is in the ON position is added together to form the numerical address of the controller.

The example below shows the switches 1, 2 and 4 on the ON position. So the corresponding values are 1, 2 and 8, giving an address sum of 11. (1+2+8=11)

The Proton network allows a maximum of 127 addresses, therefore 127 controllers.

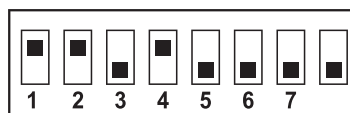

Figure 3 - Addressing Dipswitches



Input and Output Identification

All the inputs and outputs of the C1050 use pluggable screw type terminal blocks with elevator style clamping, which make connections easier and more secure.

The C1050 FlexIO Controller has two separate communication ports offering the same functionality on each. Both act as ports for incoming Modbus communications from other Proton devices or interfaces, such as a Network Controller or remote computer with Proton Focus software.

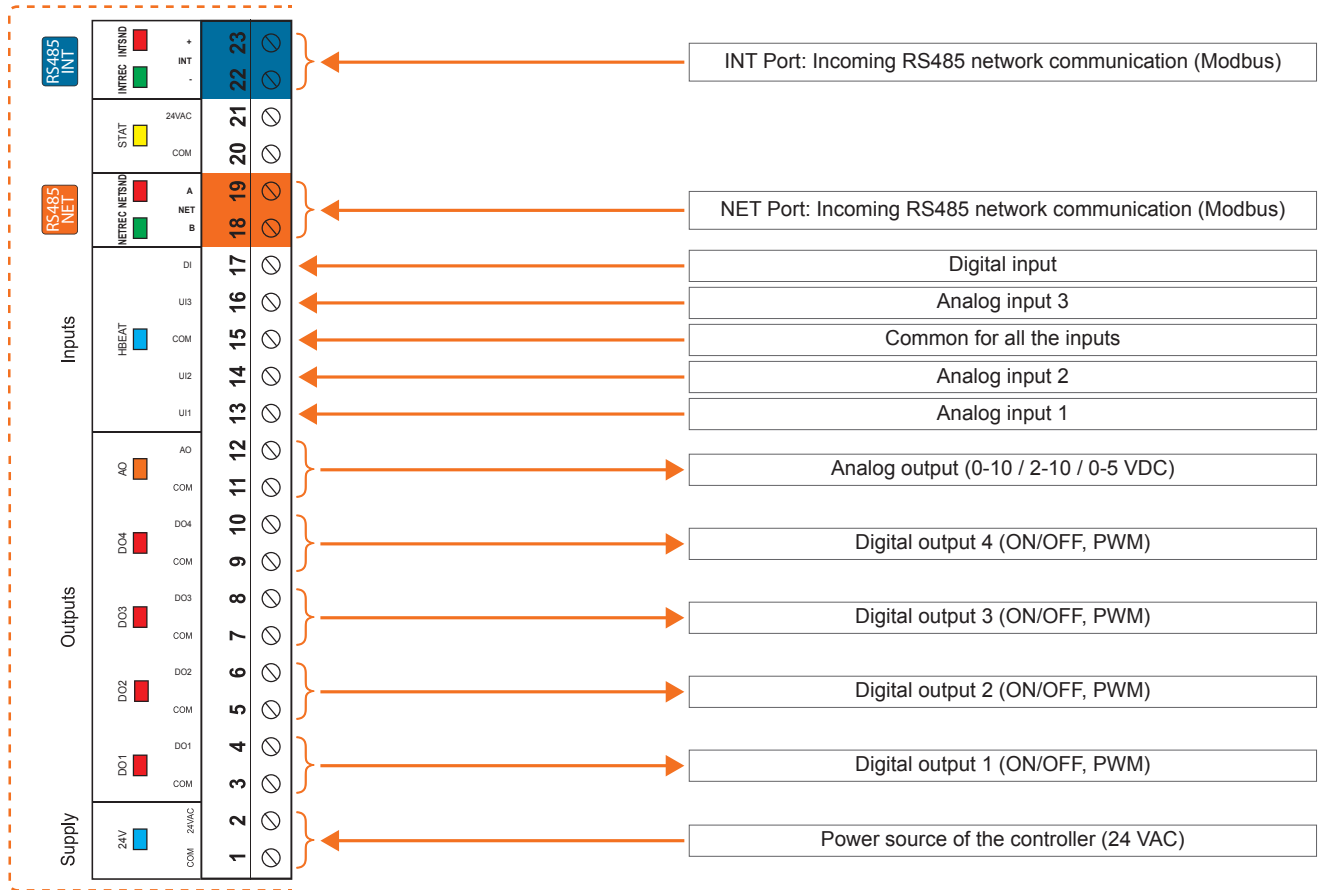

Figure 4 - Input and Output Identification



Analog Input

The C1050 series controllers are equipped with three general purpose analog inputs. These inputs can be configured to receive signals of the following types:

- Thermistor (Ω)
- 0-5V
- 4-20mA
- 0-10V

When a thermistor is used, the thermistor must be 10K Ω TYPE 3.

Each C1050 analog input is equipped with a fast-switching barrier diode to protect against surges and short circuits.

By default, the C1050-CHL analog inputs are set up for thermistor mode. The input signal mode can be changed by setting jumpers U1, U2 and U3, situated inside the casing, in the desired position:

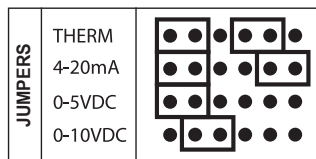

Figure 5 - Analog input

For the C1050 Digital Input, it can only accept contact signals.

Displayed below are examples of input wiring for most signal types. It is important to also configure the input appropriately in the controller's software configuration.

Signal: Thermistor

The C1050 FlexIO controller inputs can be used to monitor temperatures. The temperature sensors used are standard 10k Ω type 3 thermistors.

The outside air temperature and supply air temperature can optionally be provided by an alternate source, such as a network master. If a network controller is present on the network, it can retrieve the outside temperature reading from one controller and distribute it to any other controllers on the network.

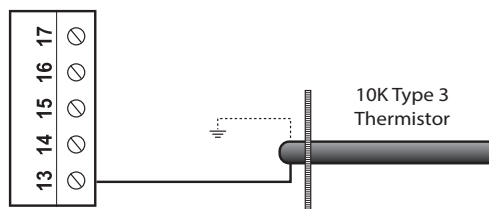

Figure 6 - Connecting a temperature sensor to analog input 1



Signal: Contact

The C1050 FlexIO controller inputs can be used to monitor digital contacts. Please refer to Figure 7 to see how to correctly connect them.

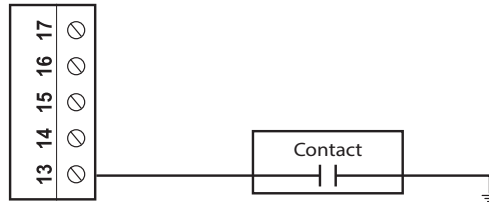

Figure 7 - Connecting a dry contact to analog input 1

Signal: Voltage

The C1050 FlexIO controller inputs can be used to monitor the voltage signal produced by a variety of transducers (such as pressure, gas, humidity and more). Please refer to Figure 8 for correct wiring.

Note: When nothing is connected, the input will read the maximum possible reading.

It is important to ensure that the sensor shares the **same common** as the C1050 so that there is no 24 VAC feedback sent back to the controller, which can interfere with the controller's ability to maintain accurate analog input readings.

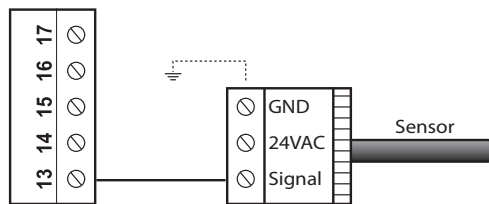

Figure 8 - Connecting voltage based sensors



Signal: Current

The C1050 FlexIO controller inputs can be used to monitor the current signal produced by a variety of transducers (such as pressure, gas, humidity and more). Please refer to Figure 10 for correct wiring.

It is important to ensure that the sensor shares the **same common** as the C1050 so that there is no 24 VAC feedback sent back to the controller, which can interfere with the controller's ability to maintain accurate analog input readings.

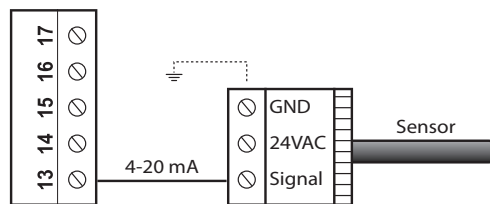

Figure 9 - Connecting current based sensors



Outputs

The C1050 FlexIO controller contains 5 customizable outputs; four triac ON/OFF outputs (24VAC) and one analog output (0-10VDC). Output configuration is performed via the Proton Focus software.

An integrated resettable fuse protects **each** of the outputs of the C1050 against current surges and short circuits. This protection will cut the current to the output as soon as an overload condition is detected. The fuse is round and yellow-colored which, upon a short circuit condition, will heat up and change to orange. When the faulty wiring or circuit is fixed, the fuse will automatically reset and allow current to flow through the output again.

Output Specifications

Output	Type	Action
DO 1	Triac source 24VAC, Max Current: 300 mA	On-or-Off / Pulse Width Modulation
DO 2	Triac source 24VAC, Max Current: 300 mA	On-or-Off / Pulse Width Modulation
DO 3	Triac source 24VAC, Max Current: 300 mA	On-or-Off / Pulse Width Modulation
DO 4	Triac source 24VAC, Max Current: 300 mA	On-or-Off / Pulse Width Modulation
AO	Configurable Analog Output: - 0 to 10 VDC - 2 to 10 VDC - 0 to 5 VDC Max Current: 40 mA	On-or-Off / Pulse Width Modulation / Modulating Proportional

Configuration of Digital Outputs

The digital triac outputs are configurable (SOURCE/SINK) via a switch located on the board. Simply move the switch to obtain either a SOURCE active output (1) or a SINK passive output (2).

1) Switch position to obtain a SOURCE **active output**:

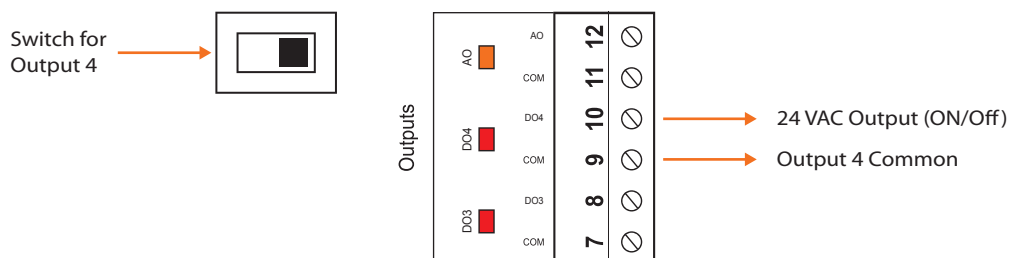

Figure 10 - Output in SOURCE mode



2) Switch position to obtain a SINK *passive output*:

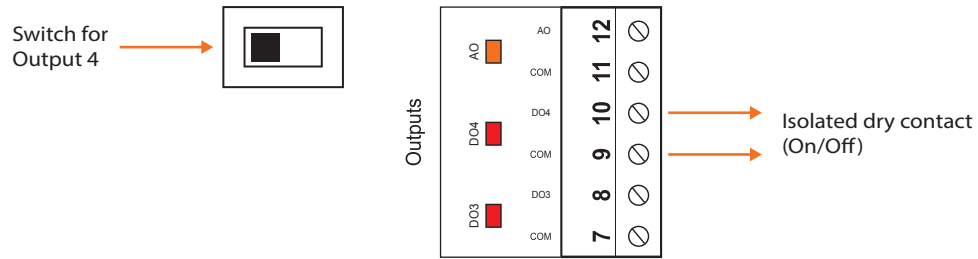

Figure 11 - Output in SINK mode

Typical Connection of Digital Outputs

Two types of configurations are possible:

1) Active output (SOURCE). The C1050 is actively powering the load.

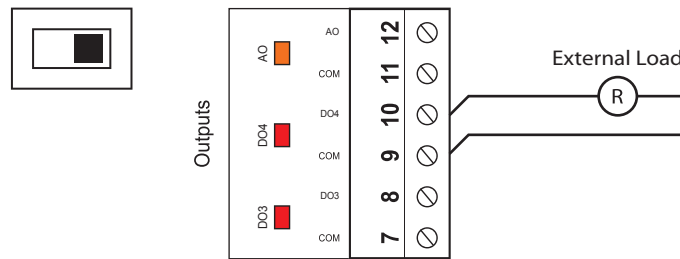

Figure 12 - Connection of active outputs 3 and 4

2) Passive output (SINK). The C1050 opens and closes a contact to allow an external source to power the load.

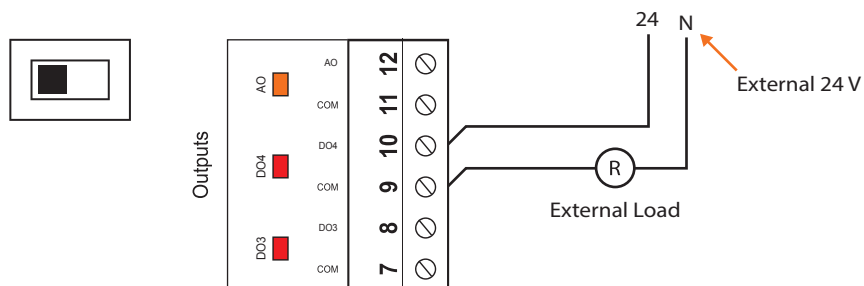

Figure 13 - Connection of passive outputs 3 and 4



Typical Connection of Analog Outputs

Two types of configuration are possible:

- 1) The C1050 powers the load and provides a control signal.

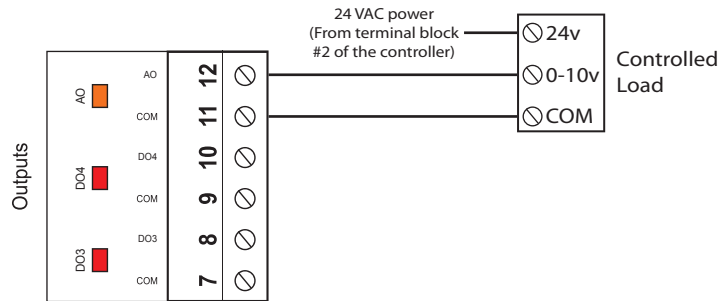

Figure 14 - Connecting the analog output (controller powered)

- 2) The C1050 only provides the control signal to the load, which is powered by an external source.

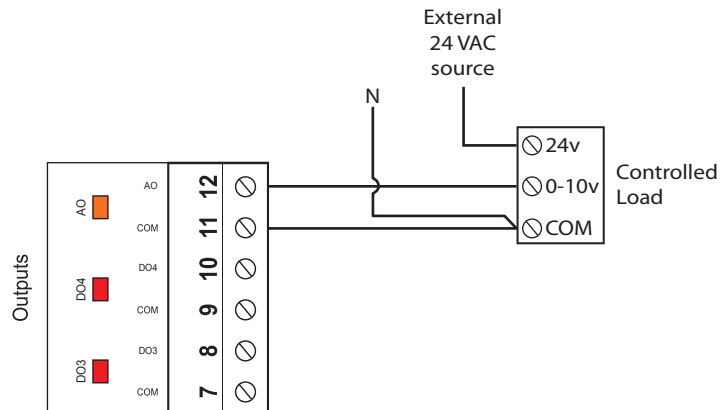

Figure 15 - Connecting the analog output (external power)



Power Source

The Proton C1050 controller is powered by a 24 VAC power source connected using the "COM" terminal and the "24 VAC" terminal. The common for all inputs and outputs are the same as the power source's common (exception: when an output is set to passive, the common for this output will not correspond to the power source common). All output power sources also originate from the controller's power source.

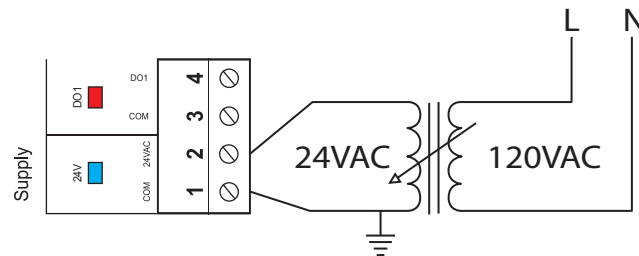

Figure 16 - Connecting the 24VAC power source

Network Communication

The Proton C1050 controller works autonomously or networked. When networked, it will communicate in real-time with other controllers. The C1050 controller's default communication protocol is Modbus RTU over RS485. The addressing is done with the addressing dipswitch located on the C1050 board (see Figure 3). The network connections are made using the NET terminal block located on the Proton C1050 controller.

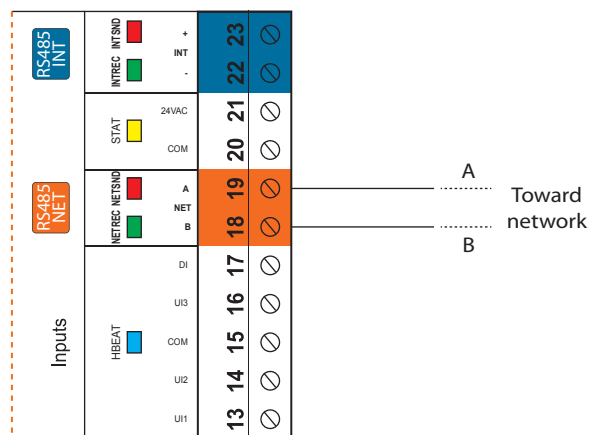

Figure 17 - Connecting to the network



Technical Specifications

Supply: 24 VAC \pm 10%, 50/60 Hz, Class 2

Consumption: 2 VA (Consumption), 32 VA (Input)

Inputs: 3 analog inputs with individually configurable signal ranges (thermistor, dry contact, 0-5 VDC, 1-5 VDC, 0.5-4.5 VDC, 0-10VDC), and 1 digital input

Digital outputs: 4 triac outputs, 10-30 VAC source or sink, 300 mA max (resettable fuse)

Analog output: 1 output 0-10 VDC / 2-10 VDC / 0-5 VDC, 40 mA max (resettable fuse)

Indication lights (LED): State of each output / Communication / Supply / State of microprocessor

Microprocessor: PIC18F6722, 8 bits, 40 MHz, 128KB FLASH memory

Casing: Molded ABS, UL94-HB

Communication: Modbus RTU (RS485), up to 127 nodes

Baud rate: 9600, 19200, 38400, 57600, 76800, 115200

Connection: Removable screw-type terminal blocks (16 AWG max)

Dimensions: 6.2" x 5.2" x 2.5" (157 mm x 132 mm x 64 mm)

Weight: 0.85 lbs (0.39 kg)

Environment: -4 to 122 °F (-20 to 50 °C) Non-Condensing

Certification: UL916 Energy Management Equipment, CAN/CSA-C22.2, RoHS, FCC part 15: 2012 class B

The performance specifications are nominal and conform to acceptable industry standards. Prolon Inc. will not be liable for damages resulting from misapplication or misuse of its products.



Compliance

- FCC Compliant to CFR47, Part 15, Subpart B, Class B
- Industry Canada (IC) Compliant to ICES-003, Issue 5: CAN ICES-3 (B)/NMB-3(B)
- RoHS Directive (2002/95/EC)

FCC User Information

This device complies with Part 15 of the FCC Rules. Operation is subject to the following two conditions: (1) this device may not cause harmful interference, and (2) this device must accept any interference received, including interference that may cause undesired operation.

Caution: Any changes or modifications not approved by Prolon can void the user's authority to operate the equipment.

Note: This equipment has been tested and found to comply with the limits for a Class B digital device, pursuant to part 15 of the FCC Rules. These limits are designed to provide reasonable protection against harmful interference in a residential installation. This equipment generates, uses and can radiate radio frequency energy and, if not installed and used in accordance with the instructions, may cause harmful interference to radio communications. However, there is no guarantee that interference will not occur in a particular installation. If this equipment does cause harmful interference to radio or television reception, which can be determined by turning the equipment off and on, the user is encouraged to try to correct the interference by one or more of the following measures:

- Reorient or relocate the receiving antenna.
- Increase the separation between the equipment and receiver.
- Connect the equipment into an outlet on a circuit different from that to which the receiver is connected.
- Consult the dealer or an experienced radio/TV technician for help.

Industry Canada

This Class (B) digital apparatus meets all the requirements of the Canadian Interference-Causing Equipment regulations.

Cet appareil numérique de la Classe (B) respecte toutes les exigences du Règlement sur le matériel brouilleur du Canada.



Overall Dimensions

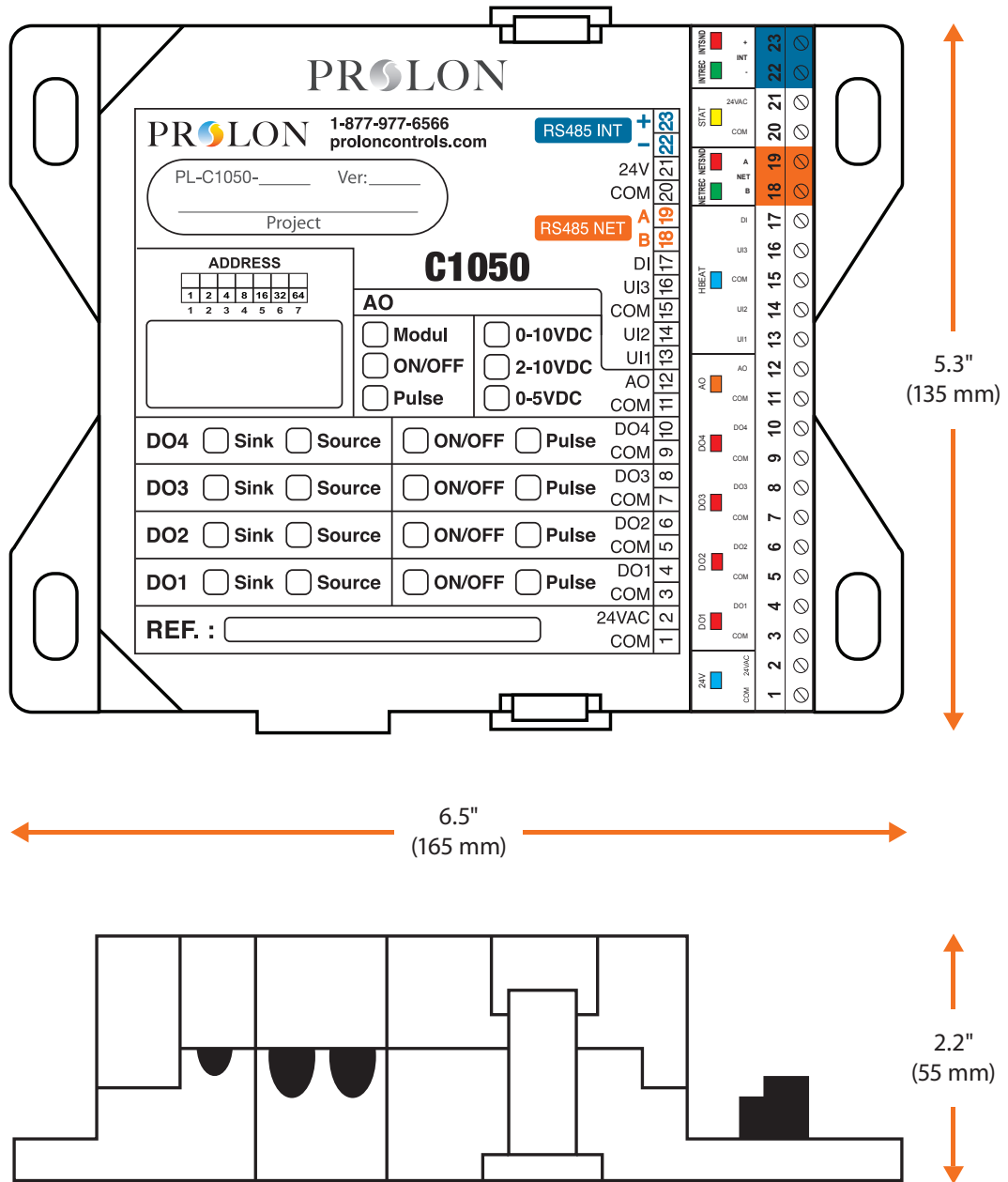

Figure 18 - C1050 Size Diagram

REV. 7.3.2

PL-HRDW-FLX-C1050-EN

© Copyright 2023 Prolon. All rights reserved.

No part of this document may be photocopied or reproduced by any means, or translated to another language without prior written consent of Prolon. All specifications are nominal and may change as design improvements are introduced. Prolon shall not be liable for damages resulting from misapplication or misuse of its products. All trademarks are the property of their respective owners.