



# PROLON

controls

---

THE NEW STANDARD IN LIGHT  
COMMERCIAL BUILDING AUTOMATION

## *Powerfully Simple Control Solutions*

Founded in 1998, Prolon specializes in manufacturing HVAC control systems designed for small to medium sized commercial buildings. Our user-friendly control line ensures easy installation and accessibility for all HVAC contractors, both mechanical and service oriented.

While many vendors focus on complicated and expensive DDC systems, offering only limited applications in their scaled-down versions, Prolon takes a different approach. We provide an application-specific, configurable control system designed to meet the needs of both retrofits and new construction. This makes Prolon highly adaptable for a wide range of small to medium-sized commercial buildings.

Prolon controllers efficiently monitor and operate various mechanical equipment, from rooftop units to boilers and exhaust fans. Designed by HVAC experts, they bridge the gap between residential controls and expensive custom DDC systems. Prolon offers high performance, simplicity, and accessibility, highlighted by features like remote access, email alerts, FREE software, and mobile apps.

Invest in Prolon controllers for a seamless blend of high performance and user-friendly accessibility in managing your mechanical equipment—an ideal choice that brings efficiency to the forefront of HVAC control solutions.





Prolon manufactures easy-to-install pre-configured HVAC controllers that have been specifically designed to meet all the requirements of today's light commercial building applications. We pride ourselves in delivering superior products and support that goes beyond our customers' expectations. Here are some key advantages of opting for Prolon solutions:

- Complete pre-configured control system for today's light commercial building needs.
- Choose networked or standalone options, connecting up to 127 devices.
- Adapt with flexible sequences for existing equipment.
- Stay informed with email alerts and mobile push notifications.
- Access FREE, user-friendly software with regular updates.
- No licensing fees or renewals required.
- Enjoy FREE remote access and mobile apps (Android + iOS).
- Get personalized technical support.

Prolon - The best choice for efficient building control solutions.

Join the 20000+ buildings controlled by Prolon solutions in North America.

- Financial institutions
- Commercial office spaces
- Educational facilities
- Healthcare facilities
- Stores / Retail outlets
- Automotive dealerships
- Places of worship





## Building Owners

Prolon offers a cost-effective control system that saves money and energy, providing comfort and efficiency to your building. With installation costs 25%-40% lower than a full DDC system, Prolon delivers identical savings and comfort through pre-programmed controllers, ensuring quick installation by your local contractor.



## Contractors

Prolon offers contractors cost-effective control solutions for small to medium-sized buildings. Application-specific controllers, designed with industry-standard sequences for various HVAC equipment, enable quick deployment and minimal setup time. Plus, Prolon controllers can seamlessly integrate into any third-party DDC system for additional versatility.



## Distributors

Prolon opens new sales opportunities for distributors and wholesalers with its user-friendly control system tailored for mechanical and service contractors. Prolon's pre-built sequences and application-specific controllers make installation and configuration easy for technicians of all levels. This allows mechanical contractors to access opportunities once limited to highly trained controls contractors.

---

***Unlock exciting opportunities by becoming a Prolon Distributor! Contact us today to embark on a rewarding partnership.***

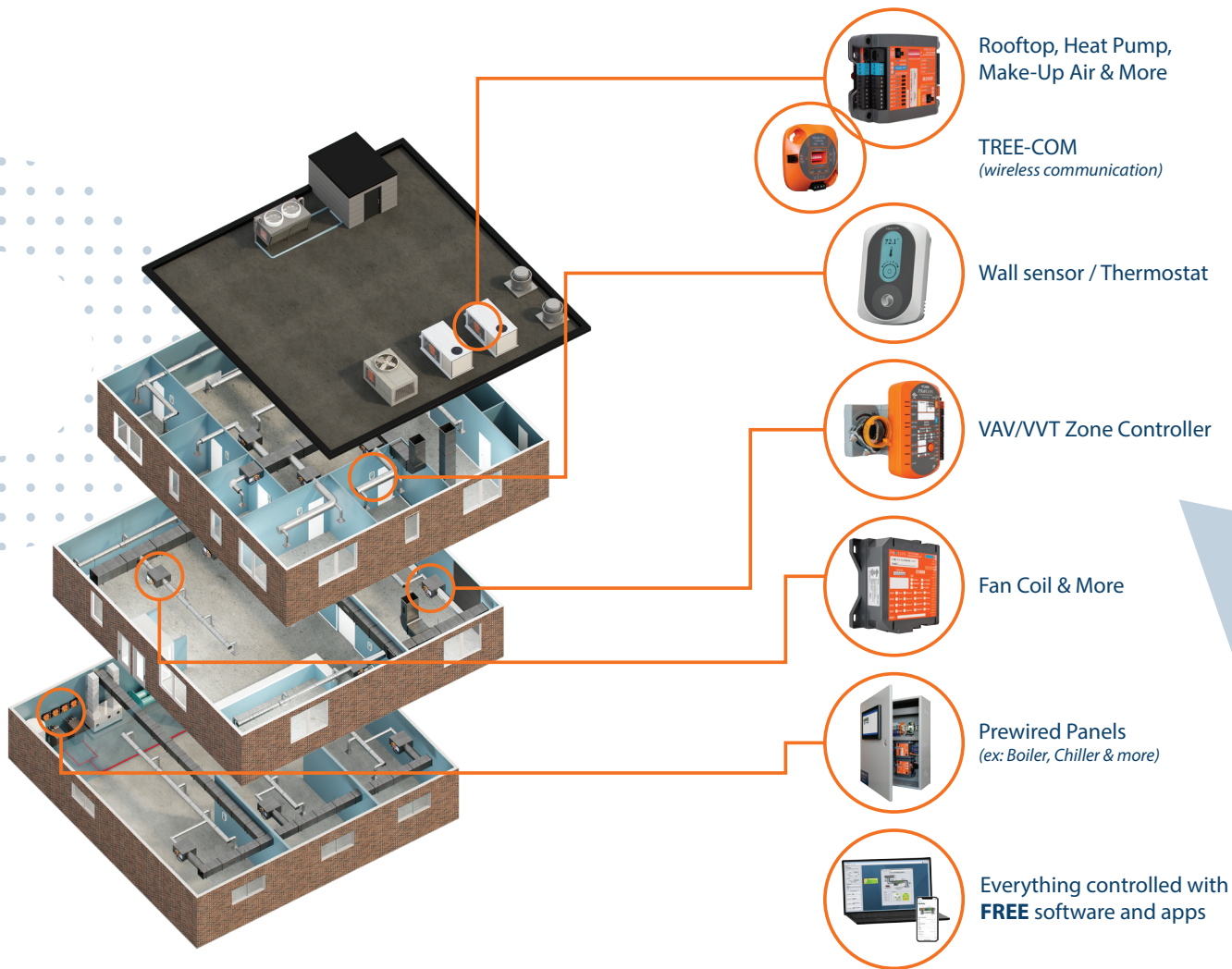



## Network Controller

- Centralize scheduling in a single device with up to 16 separate 24/7/365 schedules
- Receive email alarms or mobile push notifications to be alerted of any situation in a matter of minutes
- Monitor and configure your system remotely
- Data trending available to monitor the performance of your system



## TREE-COM

- Integrates both wired and wireless to a single system
- Range reaches up to 2,500 ft / 750 m (line of sight)
- Compatible with all ProLon Controllers
- A single “root” node can connect to one or more “leaf” nodes in a system.
- “Root” and “leaf” nodes may be used to replace wire at any point in the network.
- Over the air updates



## Digital Wall Sensor

- Configurable menus for select applications
- Available with or without LCD screen, and variety of casing and label colors
- Use remote sensor(s) for space temperature averaging!

## Digital Wall Controller

- Standalone or networked
- Configurable menus on the digital display
- Control fans, valves and baseboards
- Radiant floor sequence available



## VAV Controller

- Stand-alone or networked
- Pressure Dependent or Pressure Independent
- VAV and VVT configurations out of the box
- Multizone sequence available
- Compatible with PIU's, hot water/electric reheat coils, in-floor heating and more
- Perfect for pneumatic retrofits



Prolon offers a full range of prewired UL-certified controller panels, ensuring effortless repeatable installation for any project. The compact design and large touch-screen enables easy deployment of individual or multiple panels and provides customers with a cost-effective, professional and certified-safe solution.



**M2000 & C1050 Controllers**

### Rooftop Controller

- Compatible with both VAV & VVT systems
- Available for single-space rooftop units
- Internal schedule with 24/7/365 scheduling
- Demand-control ventilation available
- Dehumidification control

### Heat Pump Controller

- Water or Air sourced Heat Pumps
- Compatible with dual fuel units
- Control multiple compressors, auxiliary heat, fan, and economizer
- Multiple safety sequences to ensure maximum protection of your equipment!

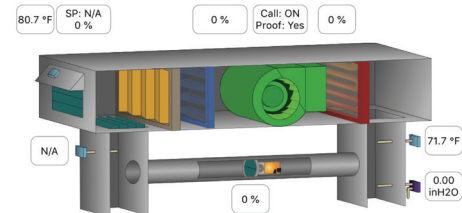

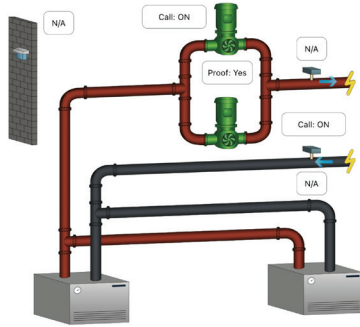

## Boiler Controller

- 4x boiler stages or modulating boiler
- 2x pumps (with fail-over sequence)
- Lead/Lag + Equal runtime sequences
- Loop temperature setpoint with outside reset scale

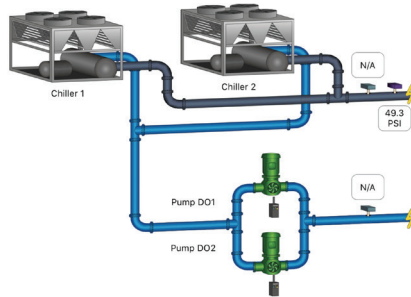

## Chiller Controller

- Designed for air cooled and water cooled chiller systems- 4x chiller stages
- 2x pumps (with fail-over sequence)
- Loop temperature setpoint with outside reset scale
- Lead/lag

## FlexIO Controller

- Control temperature, pressure, humidity, flow, level and much more
- Set up a controller to do exactly what you need it to do in a matter of minutes!
- Configure it for multiple side loops
- Great for monitoring

## Water Loop Controller

- Control tower damper or bypass valve
- Spray pump
- Staged or modulating tower fan
- One stage of reheat boiler control

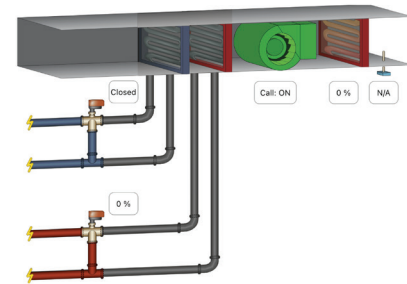

## Fan Coil Controller

- 2-pipe or 4-pipe units
- ON-OFF or modulating valve control
- Electric reheat options available
- Multispeed fan control

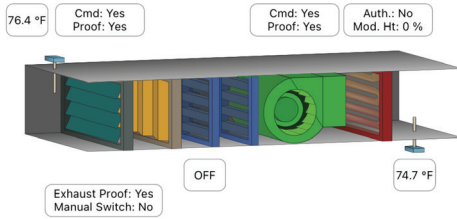

## Make-Up Air Controller

- 100% outside air or 80/20 units
- On/Off or modulating fan control
- Modulating heat
- Staged or modulating cooling

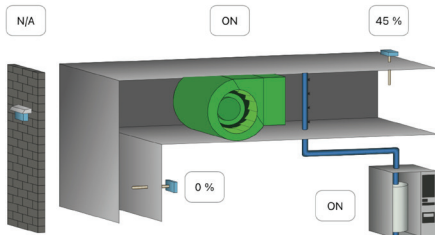

## Humidity Controller

- On/Off or modulating humidifiers
- Can work with an RTU controller or standalone for both humidification and dehumidification
- Dehumidify with existing HVAC equipment or separate dedicated equipment
- Outside air setpoint reset

## Prolon Focus Software

- Prebuilt graphics package
- Graphics adapt as you configure
- Free software for Windows and macOS

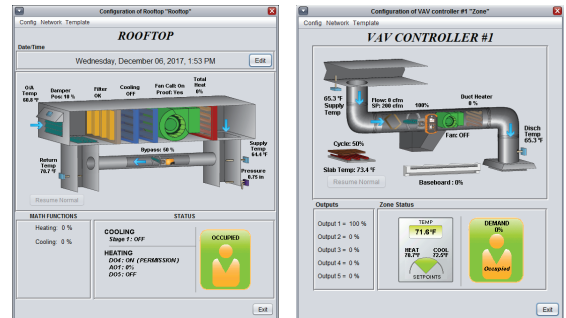
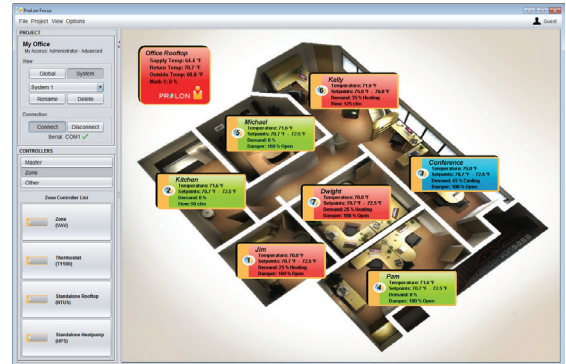

- Experience unprecedented ease in accessing a system right from the palm of your hand.
- View equipment and set up sequences from anywhere!
- Connect easily through the Internet or Bluetooth.

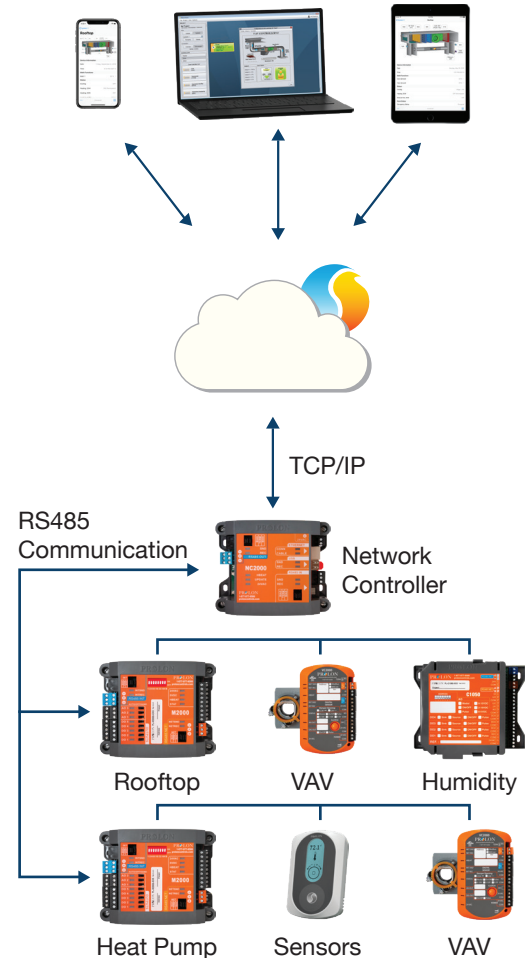
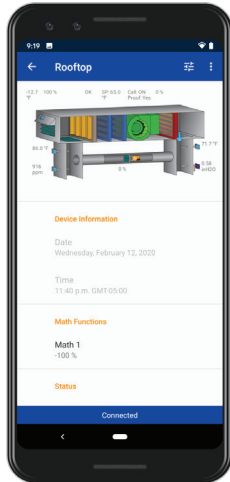
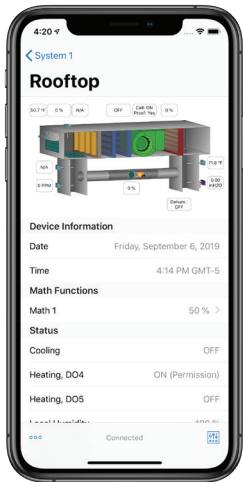



*We Make It Easy!*  
Engineering Drawings and Sequences

*We are a phone call away*

Prolon simplifies your project design by offering a comprehensive package of pre-designed engineering drawings and sequences. Whether you need a clear system view, detailed wiring schematics, or a customized sequence of operation, Prolon has you covered. Plus, all documents are conveniently available in PDF, CAD and MS Office formats (Word/Visio), ensuring flexibility and compatibility with your preferred tools. Streamline your project's design process with Prolon's ready-to-use resources.

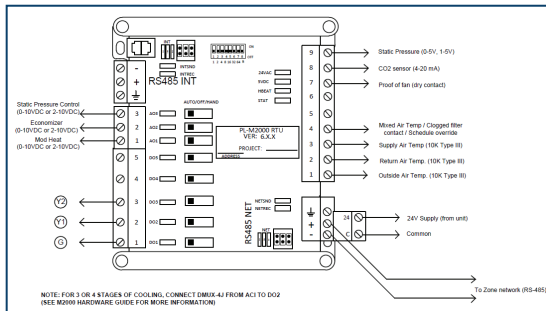
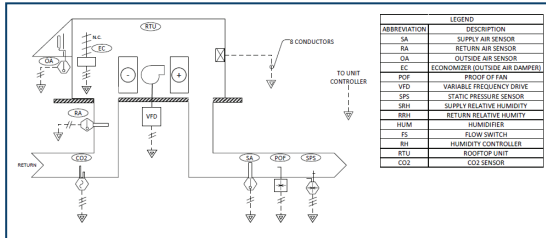

Prolon Controls offers the best training and FREE tech support in the industry.

Reach out to us for fast, personalized assistance with any questions you may have.



**Call us toll-free at  
1-877-977-6566**

*We Got You Covered  
With Over 120 Locations*

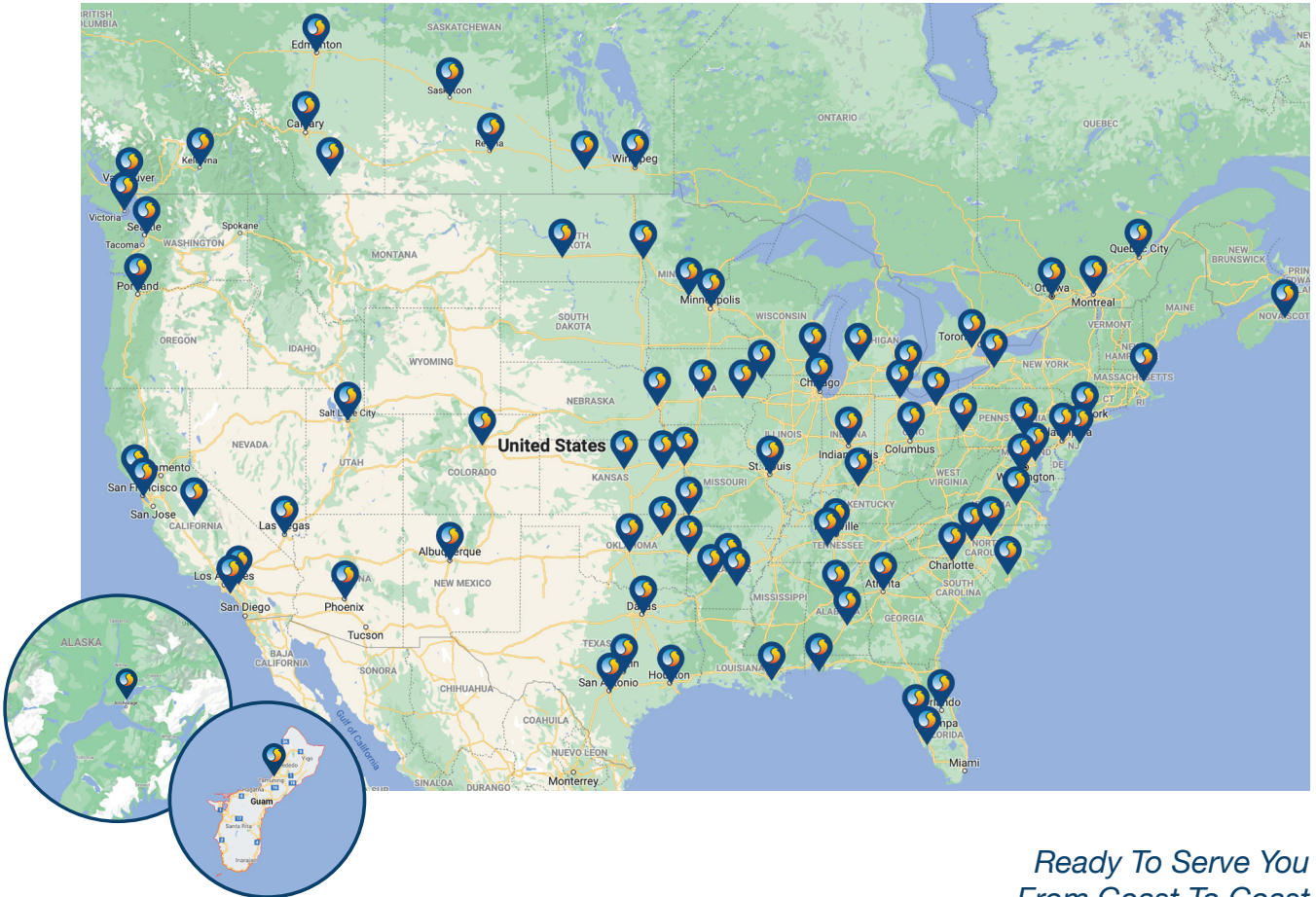

*Ready To Serve You  
From Coast To Coast*

# PROLON

controls



ProLon Head Office  
17510 Charles street, Suite 100  
Mirabel, Quebec, J7J1X9

**Phone : 450 973-5100**  
**Toll Free : 1 877 977-6566**

