



# HARDWARE GUIDE

## Chiller Controller M2000 Series

---

Specifications and Operational Guide

---

[www.proloncontrols.com](http://www.proloncontrols.com) | [info@proloncontrols.com](mailto:info@proloncontrols.com)  
17 510, rue Charles, Suite 100, Mirabel, QC, J7J 1X9



# Table of Contents

<b>General Information .....</b>	<b>4</b>
PL-M2000 Chiller Controller .....	4
Description.....	4
General Behavior .....	4
<b>Operating Sequence .....</b>	<b>5</b>
Pump.....	5
Water Supply Setpoint.....	5
Chiller Stages.....	5
Pressure Control.....	5
<b>Components .....</b>	<b>6</b>
Component Identification.....	6
LEDs and Switches.....	7
HAND/OFF/AUTO Switches .....	8
Jumpers.....	8
Input and Output Identification.....	9
Addressing Dipswitch Configuration for Network Communication.....	10
<b>Inputs .....</b>	<b>11</b>
Temperature Sensors .....	11
Proof of Pumps .....	11
Water Pressure.....	12
Alarm Contact.....	12
<b>Outputs .....</b>	<b>13</b>
Output Specifications .....	13
Typical Connection of Triac Outputs 1 to 5.....	14
Typical Connection of Analog Outputs 1 to 3.....	14
<b>Power Source &amp; Network.....</b>	<b>15</b>
Power Source .....	15
Network Communication .....	15
<b>Technical Specifications .....</b>	<b>16</b>
<b>Compliance .....</b>	<b>17</b>
FCC User Information .....	17
Industry Canada .....	17
<b>Overall Dimensions.....</b>	<b>18</b>



## Table of Figures

Figure 1 - Component Identification.....	6
Figure 2 - LEDs Identification .....	7
Figure 3 - Location of the EXTERNAL jumpers.....	8
Figure 4 - Location of the INTERNAL jumpers.....	8
Figure 5 - INT and NET jumpers .....	8
Figure 6 - AI jumpers.....	8
Figure 7 - RJ45 Pinout.....	9
Figure 8 - Input and Output Identification.....	9
Figure 9 - Addressing Dipswitch.....	10
Figure 10 - Connecting the Temperature Sensors.....	11
Figure 11 - Connecting the Proof of Pump Contacts to the Controller .....	11
Figure 12 - Connecting the Water Pressure Sensor to the Controller.....	12
Figure 13 - Connecting the Alarm Input Contacts to the Controller .....	12
Figure 14 - Wiring Example of Digital Outputs 1 and 2.....	14
Figure 15 - Wiring Example of Analog Output 1 .....	14
Figure 16 - Connecting the 24VAC Power Source.....	15
Figure 17 - Connecting to the Network.....	15
Figure 18 - M2000 Size Diagram .....	18



### PL-M2000 Chiller Controller

#### Description

The ProLON PL-M2000 Chiller Controller is a microprocessor-based controller designed to operate chiller equipment (AIR COOLED and WATER COOLED chillers) with up to four stages, as well as the associated system pumps. It features a variety of control strategies, including outside temperature reset scales, lead-lag sequences, pump exercise intervals and more.

#### General Behavior

The ProLON M2000 Chiller controller monitors dedicated inputs and uses pre-established control sequences that drive dedicated outputs to control standard Chiller equipment. The main goal of this controller is to regulate the chilled water supply temperature. Numerous configurable parameters and sequences allow for the fine tuning of the pumps, chillers stages, target supply temperature, water pressure and a whole range of safeguards. The various programming options allow the user to incorporate lead-lag sequences into the pumps and chiller stages, specify conditions for pump activity as well as apply schedules and limits. All these parameters can be accessed and modified using the ProLON Focus software.

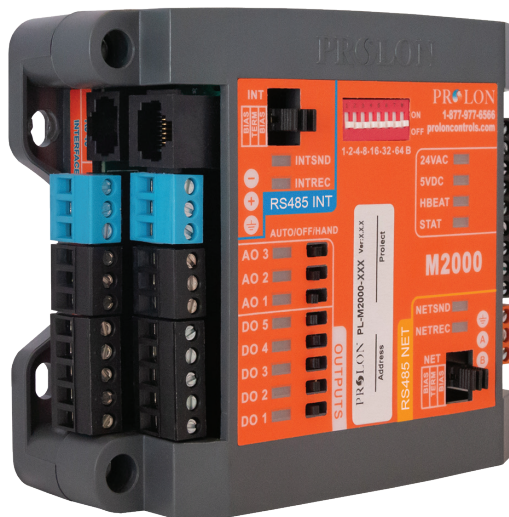



## Operating Sequence

### Pump

The PL-M2000 Chiller Controller can control systems with one or two pumps. The dual pump sequence is intended for hydronic systems where there is a secondary pump that acts as a backup to the primary pump, with both pumps being installed in parallel. Primary pump activity is based either on a schedule or on the outside air temperature, or both. The secondary pump, when required, will only be activated when there is no proof of operation of the primary pump after a configurable delay. The pumps can be setup for various lead-lag sequences wherein they will alternate between primary and secondary roles. The pumps can also be exercised after configurable periods of inactivity. Note that the chiller stages require proof of pump to activate. Alternatively, pump control can be entirely disabled, and the chillers can run without concern of pump status.

### Water Supply Setpoint

The target water supply temperature can be a simple fixed setpoint, or instead follow a reset scale based on outside temperature, return water temperature, or even on a network provided cooling demand (which usually represents an average cooling request coming from zones in the building). All scales and setpoints are fully configurable for any of the methods used above.

### Chiller Stages

Chiller activation is based on a call for cooling, which occurs when the supply temperature rises above the setpoint by a configurable margin. The PL-M2000 Chiller controller can be configured to control up to four chiller stages in various combinations (ex.: a single chiller with four stages, two dual-stage chillers, etc.). For water cooled chillers, chiller activity can be interlocked or staged down based on the entering or leaving condenser water temperature. Upon detection of multiple sequential faults, a lockout mode can be setup to block further chiller activity until a manual intervention occurs. The chiller outputs can also be set up for various lead-lag sequences to ensure an even distribution of the workload.

### Pressure Control

The PL-M2000 Chiller controller can maintain a configurable fixed water pressure setpoint by modulating analog outputs that drive a VFD attached to each pump. A PI Loop can be fine-tuned to obtain optimal results. The controller accepts both negative and positive pressure setpoints and supports a wide variety of input and output signals.



## Component Identification

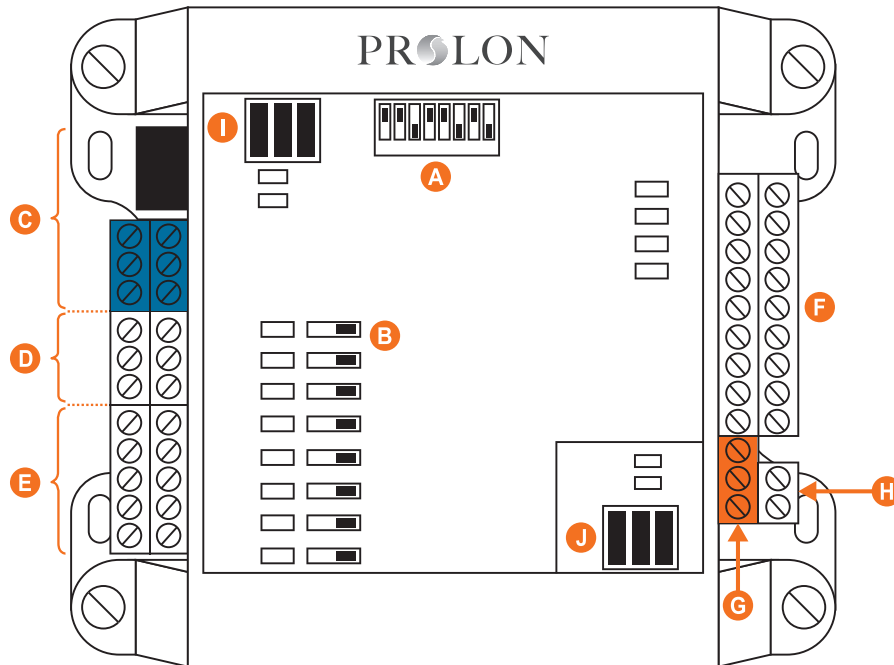

Figure 1 - Component Identification

### Legend:

- A - Addressing Dipswitch
- B - AUTO/OFF/HAND Switches
- C - RS485 INT port for interface communication (RJ45 plug and screw connectors are in parallel)
- D - Analog outputs (3)
- E - Digital outputs (5)
- F - Analog inputs (9)
- G - RS485 NET port for network communication
- H - Terminal block for 24VAC (Class 2 transformer)
- I - Jumpers for terminating and bias resistors for the INT port
- J - Jumpers for terminating and bias resistors for the NET port



## LEDs and Switches

The M2000 has various LEDs which are linked to different functions and outputs of the controller. Each LED is individually identified to help the user make a quick visual diagnostic of the controller's activity and status.

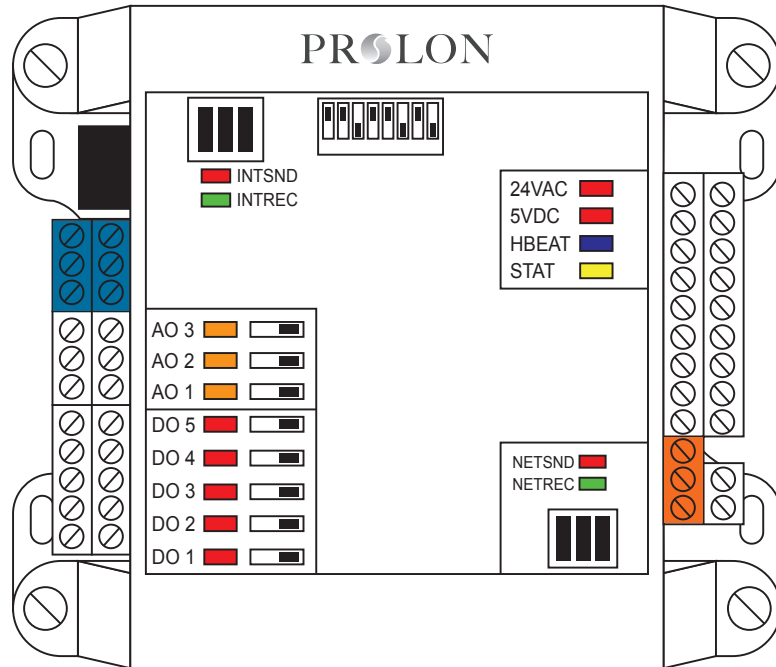

Figure 2 - LEDs Identification

### LED Descriptions

- **24 VAC:** The M2000 is receiving 24 VAC from the power source.
- **5V DC:** The microchip and other components on the M2000 are being powered successfully by a 5 VDC source derived from the 24VAC source.
- **HBEAT:** When this LED is blinking, the microchip is active and the controller's program is running (normal). When this LED is ON and steady, the M2000 is inactive and the microchip is awaiting programming (you must use Prolon's Focus software to reprogram the microchip).
- **STAT:** Reserved.
- **NETSND:** Indicates the transmission of data onto the network communication bus.
- **NETREC:** Indicates reception of data from the network communication bus.
- **INTSND:** Indicates the transmission of data onto the interface communication bus.
- **INTREC:** Indicates the reception of data from the interface communication bus.
- **AO3:** The intensity of the LED represents the voltage present on analog output 3.
- **AO2:** The intensity of the LED represents the voltage present on analog output 2.
- **AO1:** The intensity of the LED represents the voltage present on analog output 1.
- **DO5:** Represents the activity of digital output 5.
- **DO4:** Represents the activity of digital output 4.
- **DO3:** Represents the activity of digital output 3.
- **DO2:** Represents the activity of digital output 2.
- **DO1:** Represents the activity of digital output 1.



## HAND/OFF/AUTO Switches

Each output on the M2000 has a dedicated switch that lets the user manually override the activity of the output. “HAND” mode (switch at rightmost position) fully activates the output (24 VAC for digital outputs, 10VDC for analog outputs). “OFF” (switch at center) deactivates the output and “AUTO” (switch at left) returns control of the output to the program in the M2000’s microchip.

## Jumpers

The M2000 has jumpers that are externally accessible (see Figure 3), as well as jumpers that are inside the controller on the top internal board (see Figure 4), that allow for configuration of various hardware elements.

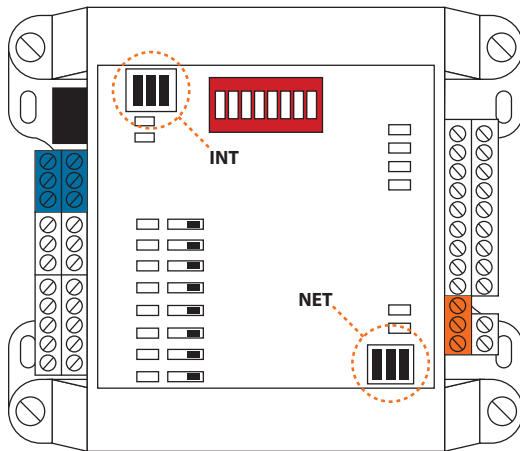

Figure 3 - Location of the EXTERNAL jumpers

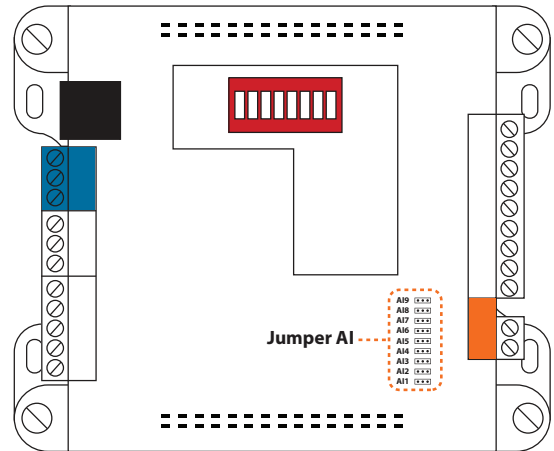

Figure 4 - Location of the INTERNAL jumpers

- **INT:** These are the jumpers for the bias and terminating resistors used for the interface communication bus. See the Pron network guide for information about bias and terminating resistors. (See Figure 5)
- **NET:** These are the jumpers for the bias and terminating resistors used for the network communication bus. See the Pron network guide for information about bias and terminating resistors. (See Figure 5)
- **AI 1 - 9:** These jumpers allow the user to select the signal mode of the associated analog input. (See Figure 6)

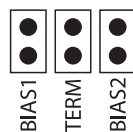

Figure 5 - INT and NET jumpers

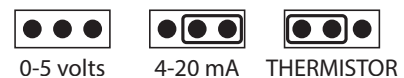

Figure 6 - AI jumpers



## Input and Output Identification

All the inputs and outputs of the M2000 use pluggable screw type terminal blocks with elevator style clamping, which make connections easier and more secure.

The M2000 Chiller Controller has 2 separate communication ports offering the same functionality on each. Both act as ports for incoming Modbus communications from other Proton devices or interfaces, such as a Network Controller or remote computer with Proton Focus software.

The "INT" Port (see below) offers dual RJ45 type connectors **in parallel** with screw type terminal blocks. The RJ45 connectors allow the use of premade CAT5 cables for simple plug-and-play RS485 communication. These RJ45 connectors follow the Modbus pinout specification for RS485 communication.

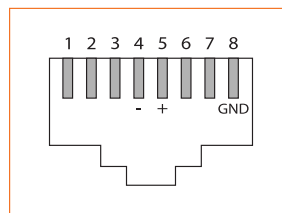

Figure 7 - RJ45 Pinout

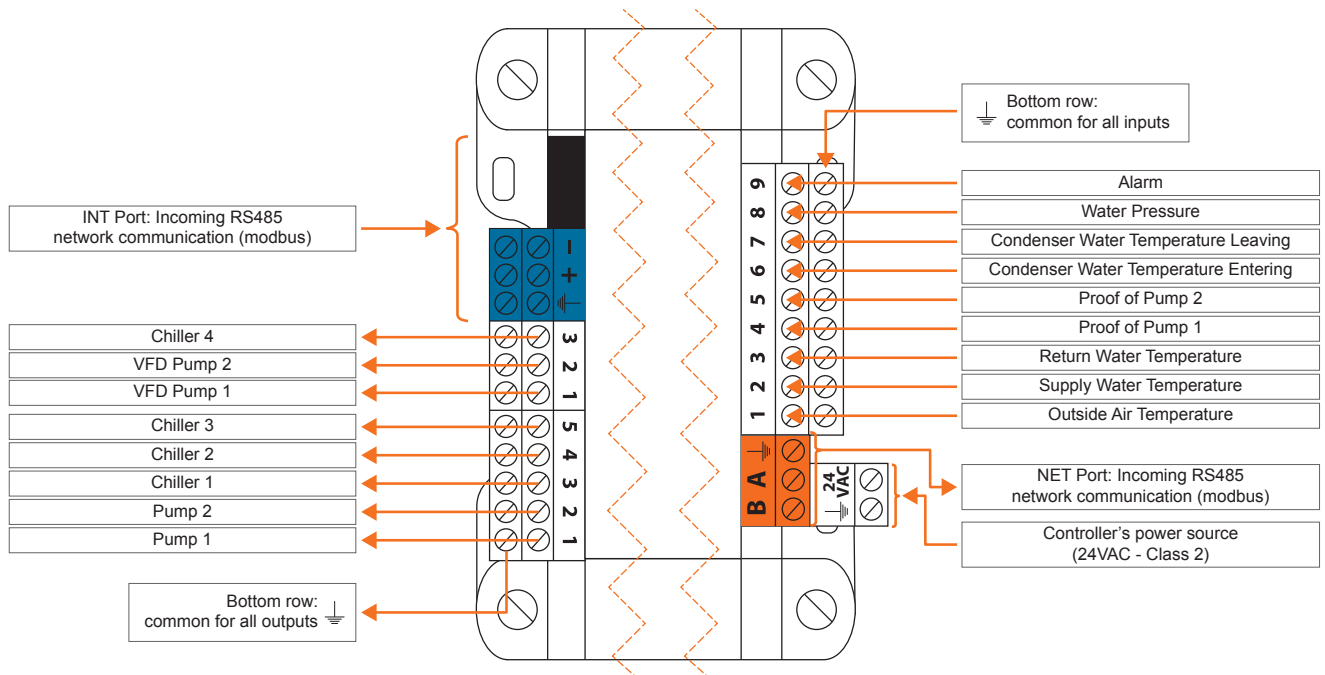

Figure 8 - Input and Output Identification



## Addressing Dipswitch Configuration for Network Communication

For proper communication, a unique address must be configured on each controller by setting the first 7 switches on the addressing dipswitch to the desired value.

These switches are numbered from 1 to 7 and represent a binary value from 1 to 64 (1, 2, 4, 8, 16, 32, and 64 respectively). The last switch (#8) is reserved. The value of each switch that is in the ON position is added together to form the numerical address of the controller.

The example in Figure 9 shows the switches 1, 2 and 4 in the ON position. Therefore, the corresponding values are 1, 2 and 8, giving an address sum of 11.

The Proton network allows a maximum of 127 addresses; therefore 127 controllers.

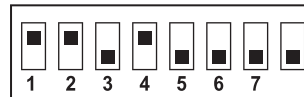

**Figure 9 - Addressing Dipswitch**



## Temperature Sensors

The M2000 Chiller Controller has five analog inputs to monitor various temperature readings, including outside air, supply water, return water, entering condenser water (ECWT) and leaving condenser water (LCWT) temperatures. The sensors used are standard 10k type 3 thermistors that share a single common connection (see Figure 10).

Note that the outside air temperature can be also be provided by an alternate source. If a network controller is present on the network, it can retrieve the outside temperature reading from one controller and distribute it to any other controllers on the network.

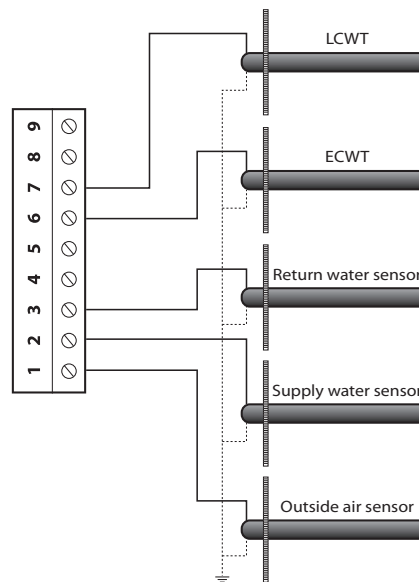

**Figure 10 - Connecting the Temperature Sensors**

## Proof of Pumps

The M2000 has two analog inputs dedicated to the proof of pump signals. Please refer to Figure 11 to see how to correctly connect them. To indicate proof of pump, the contact must be closed. If no proof of pump signal is available, you must short the corresponding input, or else the controller will interpret the absence of signal as a pump malfunction and no cooling action will be taken.

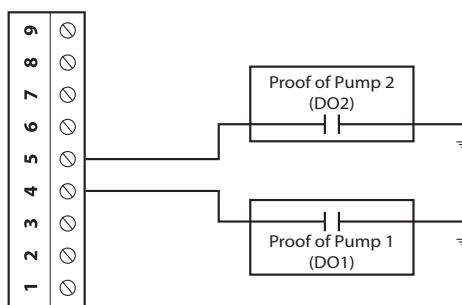

**Figure 11 - Connecting the Proof of Pump Contacts to the Controller**



## Water Pressure

Analog Input 8 on the M2000 Chiller Controller is dedicated to a water pressure sensor. The M2000 accepts various input signal voltages including 0-5VDC, 1-5VDC and 0.5-4.5VDC. Additionally, it can accept current-based signals as well, including 4-20mA and 0-20mA, but the internal jumpers first need to be set in the correct mode for current sensing (see Jumpers section).

The actual pressure range is configurable in the controller and can span anywhere between -500 to 500 PSI. Please refer to Figure 12 for correct wiring.

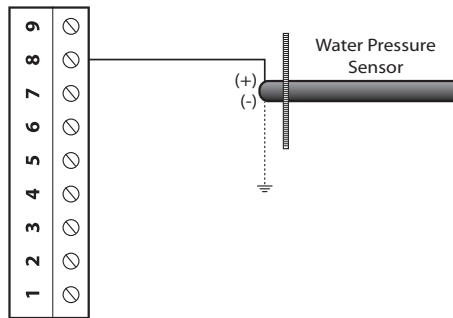

**Figure 12 - Connecting the Water Pressure Sensor to the Controller**

## Alarm Contact

Analog Input 9 on the M2000 Chiller Controller is dedicated to an Alarm Input Signal. This signal can be used to deactivate the pumps or can be used just for display purposes. Refer to Figure 13 for correct wiring.

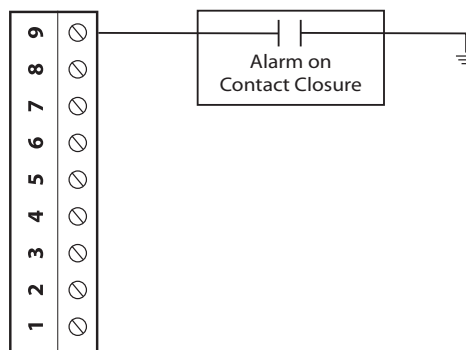

**Figure 13 - Connecting the Alarm Input Contacts to the Controller**



## Outputs

The M2000 Chiller controller contains 8 customizable outputs; five triac ON/OFF outputs (24VAC) and three analog outputs (0-10VDC). Output configuration is performed via the Prolon Focus software.

An integrated resettable fuse protects each of the outputs of the M2000 against current surges and short circuits. This protection will cut the current to the output as soon as an overload condition is detected. The fuse is a round, yellow-coloured PTC that will change to orange and heat up on an overload condition. Once power has been removed from the M2000, the fuse will cool down and automatically reset. Fix the faulty wiring and you will be able to activate the output once again.

### Output Specifications

Output	Type	Action	Application
<b>DO 1</b>	Triac source 24VAC, Max Current: 300 mA	On-or-Off	Pump 1
<b>DO 2</b>	Triac source 24VAC, Max Current: 300 mA	On-or-Off	Pump 2
<b>DO 3</b>	Triac source 24VAC, Max Current: 300 mA	On-or-Off	Chiller Stage 1
<b>DO 4</b>	Triac source 24VAC, Max Current: 300 mA	On-or-Off	Chiller Stage 2
<b>DO 5</b>	Triac source 24VAC, Max Current: 300 mA	On-or-Off	Chiller Stage 3
<b>AO 1</b>	Configurable Analog Output: - 0 to 10 VDC - 2 to 10 VDC - 0 to 5 VDC Max Current: 40 mA	Modulating Proportional	Variable Frequency Drive 1
<b>AO 2</b>	Configurable Analog Output: - 0 to 10 VDC - 2 to 10 VDC - 0 to 5 VDC Max Current: 40 mA	Modulating Proportional	Variable Frequency Drive 2
<b>AO 3</b>	Configurable Analog Output: - 0 to 10 VDC Max Current: 40 mA	On-or-Off	Chiller Stage 4



## Typical Connection of Triac Outputs 1 to 5

On the M2000 Chiller controller, all triac outputs produce a 24 VAC live voltage when activated. Note that all output voltages originate from a single voltage supply: the equipment's transformer. Consequentially, only the live side of the output connections are usually needed; these are on the top row (see Figure 14). The bottom row is the common (GND).

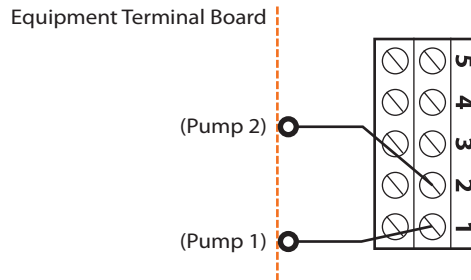

Figure 14 - Wiring Example of Digital Outputs 1 and 2

## Typical Connection of Analog Outputs 1 to 3

For all analog outputs, the common is found on the bottom row terminal block, and the active signals are found on the top row terminal block (see Figure 15).

Analog Outputs 1 and 2 are set to modulate the VFD for each pump (DC load using 0-10 VDC, 2-10 VDC or 0-5 VDC). Analog Output 3 is configured to control a 10 VDC On/Off relay that will drive Chiller Stage #4 (if applicable).

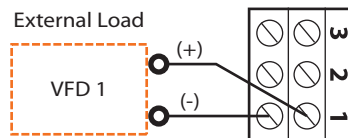

Figure 15 - Wiring Example of Analog Output 1



## Power Source & Network

### Power Source

The M2000 controller is powered by a 24 VAC power supply (class 2) by connecting the common ("C" wire) to the "COM" terminal and the live ("R" wire) to the "24 VAC" terminal (see Figure 16). The common for all inputs and outputs is the same as the power source's common. All output power sources also originate from the source transformer (class 2).

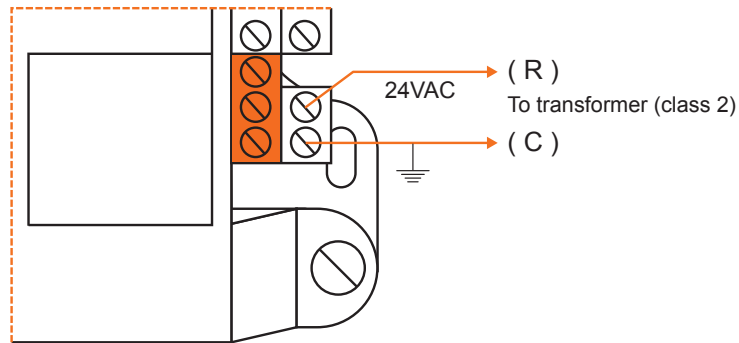

Figure 16 - Connecting the 24VAC Power Source

### Network Communication

The Proton M2000 Chiller controller is designed to work standalone or networked with Proton master controllers. When networked, the master transmits the occupancy status, outside temperature and math demand in real-time. The network connections are made using the network terminal block located on the M2000 controller (see Figure 17).

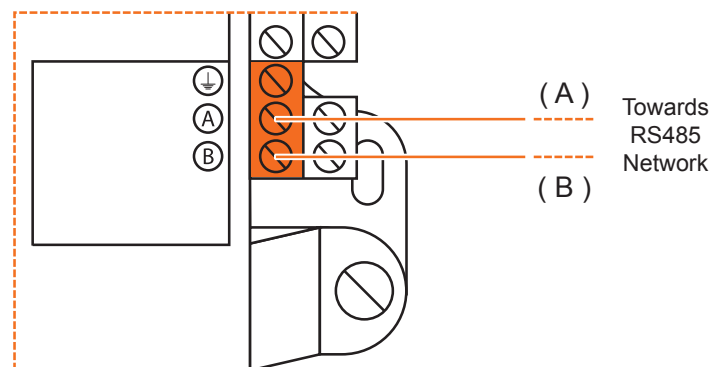

Figure 17 - Connecting to the Network



## Technical Specifications

**Supply:** 24 VAC  $\pm$ 10%, 50/60 Hz, Class 2

**Power:** 5 VA (consumption), 40 VA (input)

**Inputs:** 9 analog inputs (outside temp / supply water temp / return water temp / dry contacts for proof of pumps, entering condenser water temp, leaving condenser water temp, water pressure and alarm). Input signals (thermistor / dry contact / 4-20mA / 0-5 VDC) individually configurable for each input.

**Digital Outputs:** 5 triac outputs, 10-30 VAC source, 300 mA max (resettable fuse)

**Analog Outputs:** 3 x 0-10 VDC outputs, 40 mA max (resettable fuse)

**Indication lights (LED):** State of each output / Communication / Power / State of microprocessor

**Microprocessor:** PIC18F6722, 8 bits, 40 MHz, 128KB FLASH memory

**Casing:** Molded ABS, UL94-HB

**Communication:** Modbus RTU (RS485) up to 127 nodes

**Baud Rates:** 9600, 19200, 38400, 57600, 76800, 115200

**Connection:** Removable screw-type terminal blocks (max 16 AWG) and RJ45 modular jacks

**Dimensions:** 5.39" x 4.41" x 2.25" (137 mm x 112 mm x 57 mm)

**Weights:** 1.05 lbs (0.48 kg)

**Environment:** -4 to 122 °F (-20 to 50 °C) Non-Condensing

**Certification:** UL916 Energy Management Equipment, CAN/CSA-C22.2, RoHS, FCC part 15: 2012 class B

*The performance specifications are nominal and conform to acceptable industry standards. Prolon Inc. will not be liable for damages resulting from misapplication or misuse of its products.*



## Compliance

- cULus Listed; UL 916 Energy Management Equipment, File E364757, Vol.1
- CAN/CSA-C22.2 No. 2015-12, Signal Equipment
- FCC Compliant to CFR47, Part 15, Subpart B, Class B
- Industry Canada (IC) Compliant to ICES-003, Issue 5: CAN ICES-3 (B)/NMB-3(B)
- RoHS Directive (2002/95/EC)

### FCC User Information

---

This device complies with Part 15 of the FCC Rules. Operation is subject to the following two conditions: (1) this device may not cause harmful interference, and (2) this device must accept any interference received, including interference that may cause undesired operation.

**Caution:** Any changes or modifications not approved by Prolon can void the user's authority to operate the equipment.

**Note:** This equipment has been tested and found to comply with the limits for a Class B digital device, pursuant to part 15 of the FCC Rules. These limits are designed to provide reasonable protection against harmful interference in a residential installation. This equipment generates, uses and can radiate radio frequency energy and, if not installed and used in accordance with the instructions, may cause harmful interference to radio communications. However, there is no guarantee that interference will not occur in a particular installation. If this equipment does cause harmful interference to radio or television reception, which can be determined by turning the equipment off and on, the user is encouraged to try to correct the interference by one or more of the following measures:

- Reorient or relocate the receiving antenna.
- Increase the separation between the equipment and receiver.
- Connect the equipment into an outlet on a circuit different from that to which the receiver is connected.
- Consult the dealer or an experienced radio/TV technician for help.

### Industry Canada

---

This Class (B) digital apparatus meets all the requirements of the Canadian Interference-Causing Equipment regulations.

Cet appareil numérique de la Classe (B) respecte toutes les exigences du Règlement sur le matériel brouilleur du Canada.



# Overall Dimensions

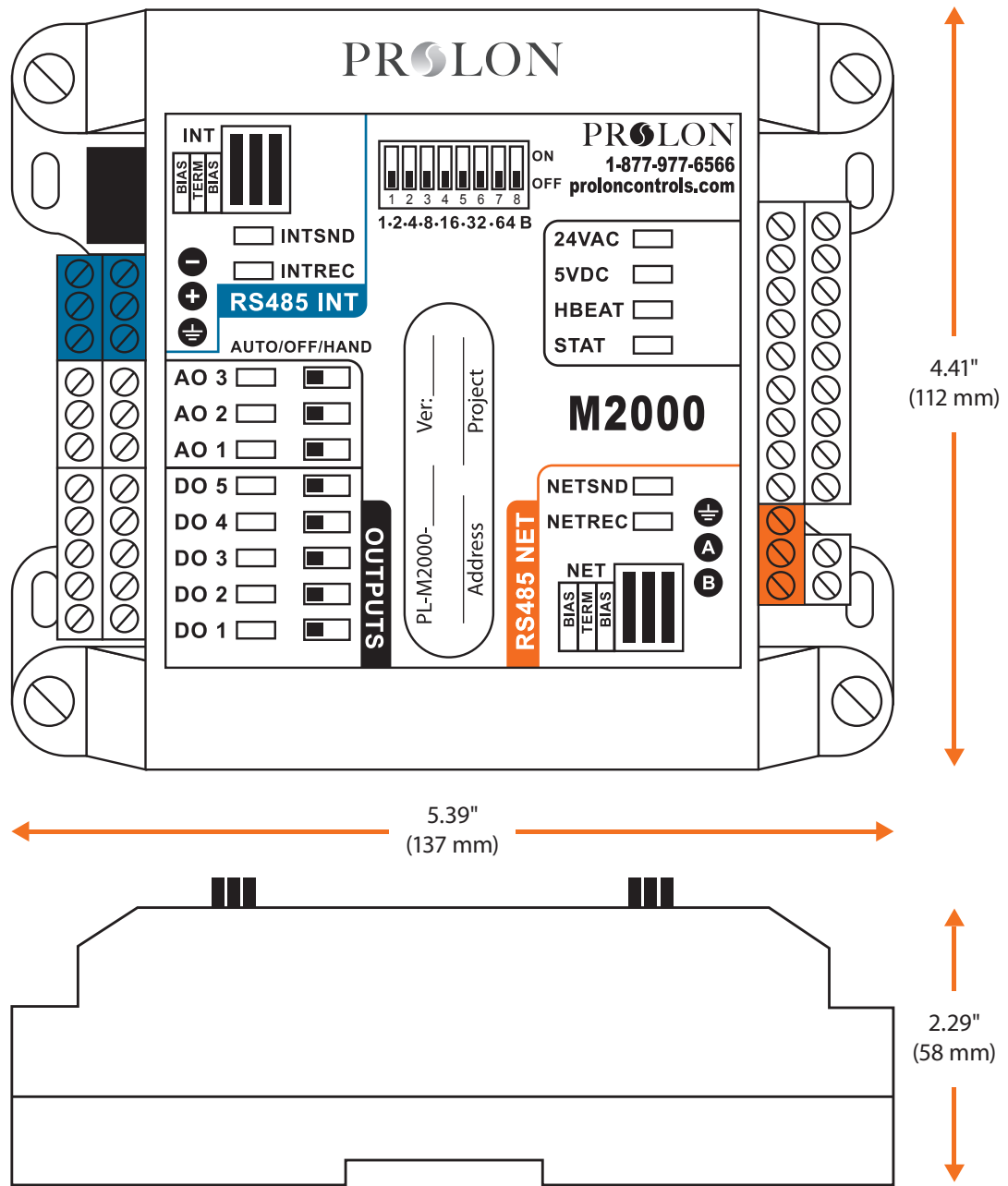

Figure 18 - M2000 Size Diagram

REV. 7.3.5

PL-HRDW-CHL-M2000-C/F-EN

© Copyright 2026 Prolon. All rights reserved.

No part of this document may be photocopied or reproduced by any means, or translated to another language without prior written consent of Prolon. All specifications are nominal and may change as design improvements are introduced. Prolon shall not be liable for damages resulting from misapplication or misuse of its products. All trademarks are the property of their respective owners.