



HARDWARE GUIDE

FlexIO Controller M2000 Series

Specifications and Operational Guide

www.proloncontrols.com | info@proloncontrols.com
17 510, rue Charles, Suite 100, Mirabel, QC, J7J 1X9



Table of Contents

General Information	4
PL-M2000 FLX Controller	4
Description.....	4
Features.....	4
Components.....	5
Components Identification	5
LEDs and Switches.....	6
HAND/OFF/AUTO Switches	7
Jumpers.....	7
Input and Output Identification.....	8
Addressing Dipswitch Configuration for Network Communication.....	9
Inputs	10
Signal: Thermistor.....	10
Signal: Contact.....	11
Signal: Voltage	11
Signal: Current	12
Outputs	13
Output Specifications	13
Typical Connection of Triac Outputs 1 to 5.....	14
Typical Connection of Analog Outputs 1 to 3.....	14
Power Source & Network.....	15
Power Source	15
Network Communication	15
Technical Specifications	16
Compliance	17
FCC User Information	17
Industry Canada	17
Overall Dimensions.....	18



Table of Figures

Figure 1 - Component Identification.....	5
Figure 2 - LEDs Identification	6
Figure 3 - Location of the EXTERNAL jumpers.....	7
Figure 5 - INT and NET jumpers	7
Figure 4 - Location of the INTERNAL jumpers.....	7
Figure 6 - AI jumpers.....	7
Figure 7 - Input and Output Identification.....	8
Figure 8 - RJ45 Pinout.....	8
Figure 9 - Addressing Dipswitch.....	9
Figure 10 - Connecting a temperature sensor to analog input 1	10
Figure 11 - Connecting a dry contact to analog input 1	11
Figure 12 - Connecting a voltage based sensor to analog input 1.....	11
Figure 13 - Connecting a current based sensor to analog input 1	12
Figure 14 - Wiring example of digital outputs 1	14
Figure 15 - Wiring example of an analog output 1	14
Figure 16 - Connecting the 24VAC power source.....	15
Figure 17 - Connecting to the network.....	15
Figure 18 - M2000 Size Diagram	18



PL-M2000 FLX Controller

Description

The M2000 FlexIO is a general purpose HVAC controller whose inputs and outputs can be individually configured for use in various applications. Unlike most Prolon controllers, the FlexIO is not aimed at a specific HVAC sequence or piece of equipment, and instead can be used to perform any outlying functions that are not usually covered by existing Prolon devices. Outputs can be configured to respond to a variety of standard HVAC input signal types, ranging from temperatures, pressure, gas and more.

Features

- Many input types available: Temperature, Dry Contact, Pressure, Gas, Humidity
- Configurable names and display options for each input and output
- Configurable scales for pressure and gas inputs accommodates any sensor
- Outputs can act based on any local input, or on data received from a network master
- Can receive up to 8 different occupancy states from an NC2000, allowing for versatile lighting control
- Various output logic sequences are available: ON/OFF, PI Loop, Direct or Reverse acting
- Outputs can be interlocked with each other
- Outputs can be automatically overridden based on outside temperature and/or occupancy
- Operates standalone or can be integrated into a Prolon network

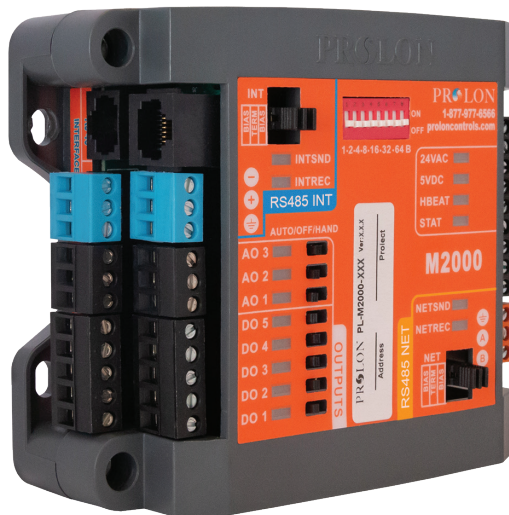



Components Identification

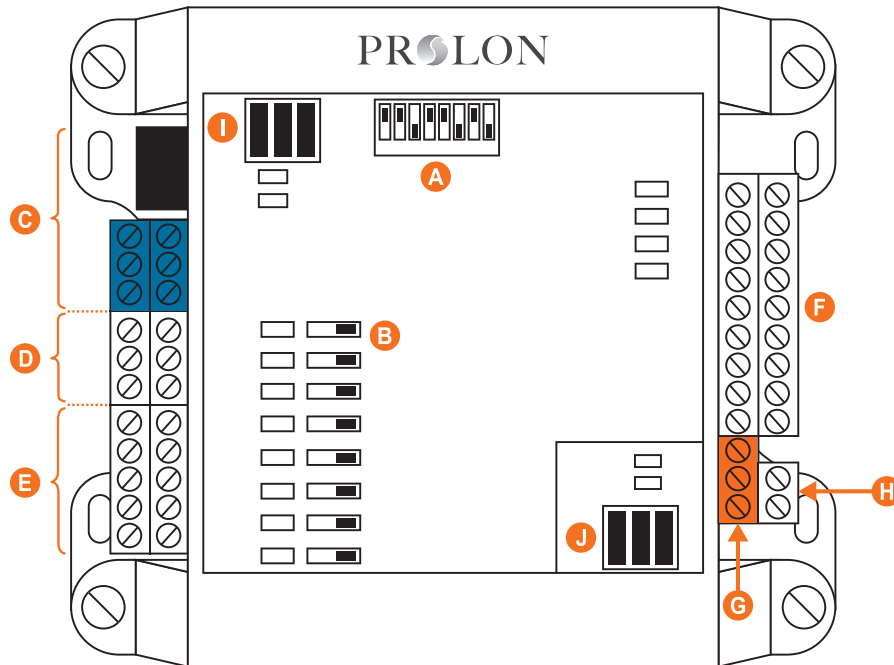

Figure 1 - Component Identification

Legend:

- A - Addressing Dipswitch
- B - AUTO/OFF/HAND Switches
- C - RS485 INT port for interface communication (RJ45 plug and screw connectors are in parallel)
- D - Analog outputs (3)
- E - Digital outputs (5)
- F - Analog inputs (9)
- G - RS485 NET port for network communication
- H - Terminal block for 24VAC (Class 2 transformer)
- I - Jumpers for terminating and bias resistors for the INT port
- J - Jumpers for terminating and bias resistors for the NET port



LEDs and Switches

The M2000 has various LEDs which are linked to different functions and outputs of the controller. Each LED is individually identified to help the user make a quick visual diagnostic of the controller's activity and status.

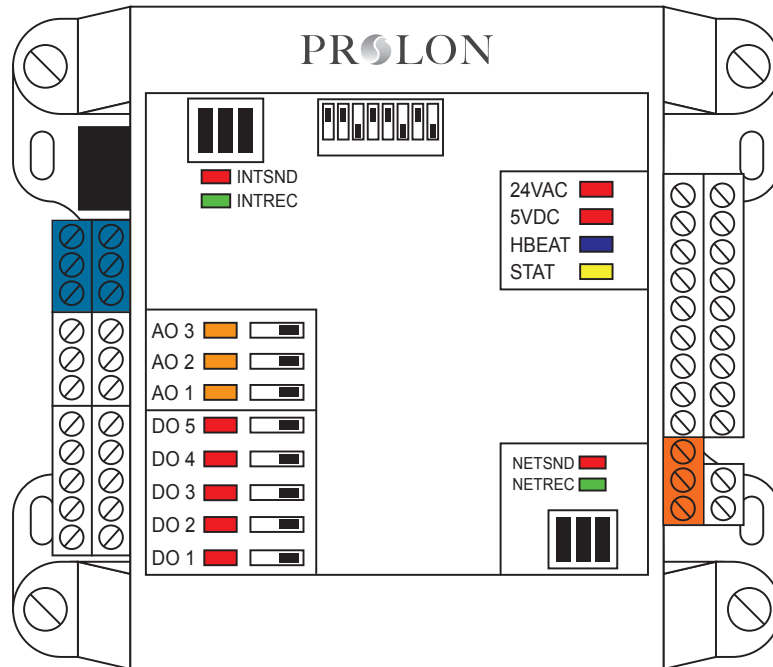

Figure 2 - LEDs Identification

LED Descriptions

- **24 VAC:** The M2000 is receiving 24 VAC from the power source.
- **5V DC:** The microchip and other components on the M2000 are being powered successfully by a 5VDC source derived from the 24VAC source.
- **HBEAT:** When this LED is blinking, the microchip is active and the controller's program is running (normal). When this LED is ON and steady, the M2000 is inactive and the microchip is awaiting programming (you must use Prolon's Focus software to reprogram the microchip).
- **STAT:** Reserved.
- **NETSND:** Indicates the transmission of data onto the network communication bus.
- **NETREC:** Indicates reception of data from the network communication bus.
- **INTSND:** Indicates the transmission of data onto the interface communication bus.
- **INTREC:** Indicates the reception of data from the interface communication bus.
- **AO3:** The intensity of the LED represents the voltage present on analog output 3.
- **AO2:** The intensity of the LED represents the voltage present on analog output 2.
- **AO1:** The intensity of the LED represents the voltage present on analog output 1.
- **DO5:** Represents the activity of digital output 5.
- **DO4:** Represents the activity of digital output 4.
- **DO3:** Represents the activity of digital output 3.
- **DO2:** Represents the activity of digital output 2.
- **DO1:** Represents the activity of digital output 1.



HAND/OFF/AUTO Switches

Each output on the M2000 has a dedicated switch that lets the user manually override the activity of the output. "HAND" mode (switch at rightmost position) fully activates the output (24 VAC for digital outputs, 10VDC for analog outputs). "OFF" (switch at center) deactivates the output and "AUTO" (switch at left) returns control of the output to the program in the M2000's microchip.

Jumpers

The M2000 has jumpers that are externally accessible (see Figure 3), as well as jumpers that are inside the controller on the top internal board (see Figure 4), that allow for configuration of various hardware elements.

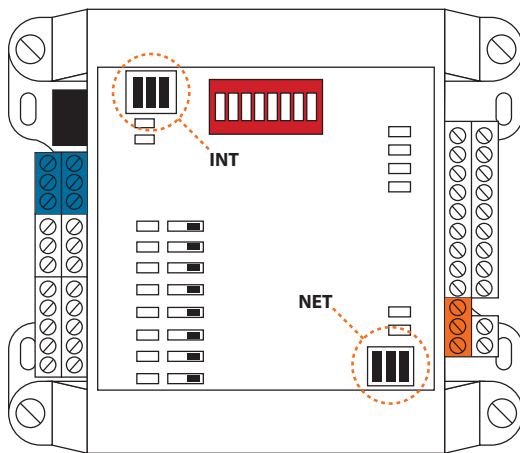

Figure 3 - Location of the EXTERNAL jumpers

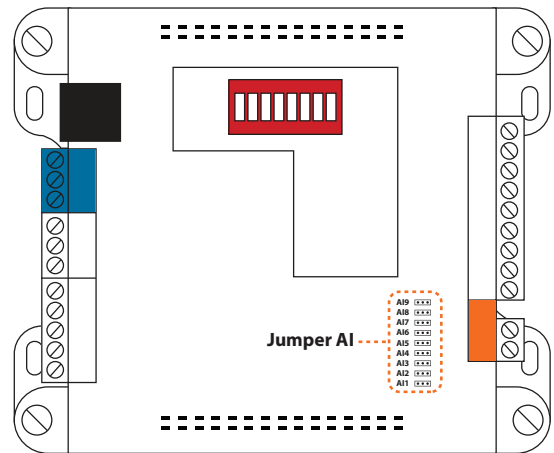

Figure 4 - Location of the INTERNAL jumpers

- **INT:** These are the jumpers for the bias and terminating resistors used for the interface communication bus. See the Proton network guide for information about bias and terminating resistors. (See Figure 5)
- **NET:** These are the jumpers for the bias and terminating resistors used for the network communication bus. See the Proton network guide for information about bias and terminating resistors. (See Figure 5)
- **AI 1 - 9:** These jumpers allow the user to select the signal mode of the associated analog input. (See Figure 6)

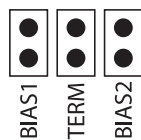

Figure 5 - INT and NET jumpers



Figure 6 - AI jumpers



Input and Output Identification

All the inputs and outputs of the M2000 use pluggable screw type terminal blocks with elevator style clamping, which make connections easier and more secure.

The M2000 FlexIO Controller has 2 separate communication ports offering the same functionality on each. Both act as ports for incoming Modbus communications from other Proton devices or interfaces, such as a Network Controller or remote computer with Proton Focus software.

The "INT" Port (see below) offers dual RJ45 type connectors **in parallel** with screw type terminal blocks. The RJ45 connectors allow the use of premade CAT5 cables for simple plug-and-play RS485 communication. These RJ45 connectors follow the Modbus pinout specification for RS485 communication.

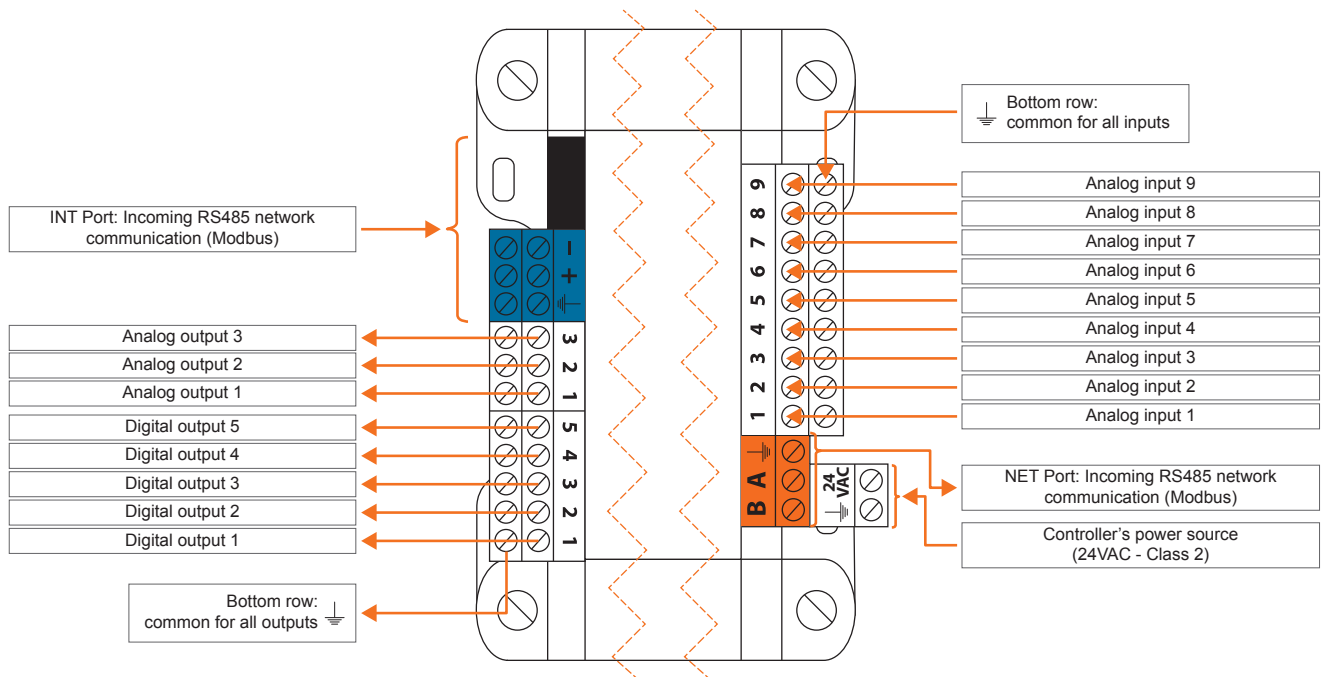

Figure 7 - Input and Output Identification

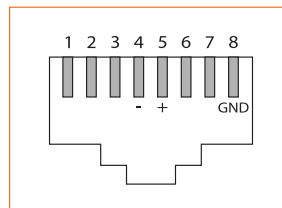

Figure 8 - RJ45 Pinout



Addressing Dipswitch Configuration for Network Communication

For proper communication, a unique address must be configured on each controller by setting the first 7 switches on the addressing dipswitch to the desired value.

These switches are numbered from 1 to 7 and represent a binary value from 1 to 64 (1, 2, 4, 8, 16, 32, and 64 respectively). The last switch (#8) is reserved. The value of each switch that is in the ON position is added together to form the numerical address of the controller.

The example in Figure 3 shows the switches 1, 2 and 4 in the ON position. Therefore, the corresponding values are 1, 2 and 8, giving an address sum of 11.

The Proton network allows a maximum of 127 addresses; therefore 127 controllers.



Figure 9 - Addressing Dipswitch



Inputs

The M2000 FlexIO controller's inputs can be configured to accept a wide range of signal types. It is important to note that depending on the chosen signal type, a modification to the input jumper configuration may be required (see p.7).

Displayed below are examples of input wiring for most signal types. It is important to also configure the input appropriately in the controller's software configuration.

Signal: Thermistor

The M2000 FlexIO controller inputs can be used to monitor temperatures. The temperature sensors used are standard 10k Ω type 3 thermistors (see Figure 10).

The outside air temperature and supply air temperature can optionally be provided by an alternate source, such as a network master. If a network controller is present on the network, it can retrieve the outside temperature reading from one controller and distribute it to any other controllers on the network.

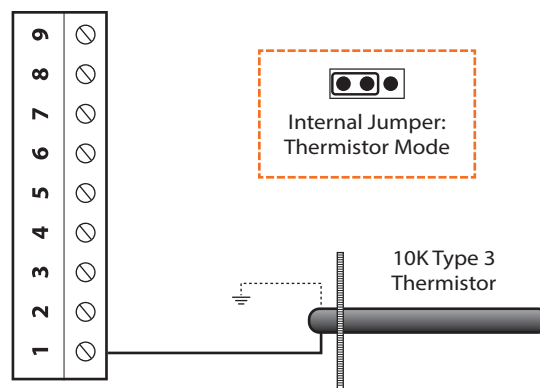

Figure 10 - Connecting a temperature sensor to analog input 1



Signal: Contact

The M2000 FlexIO controller inputs can be used to monitor digital contacts. Please refer to Figure 11 to see how to correctly connect them.

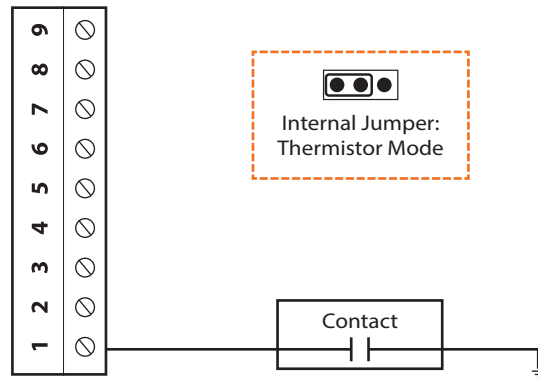

Figure 11 - Connecting a dry contact to analog input 1

Signal: Voltage

The M2000 FlexIO controller inputs can be used to monitor the voltage signal produced by a variety of transducers (such as pressure, gas, humidity and more). Please refer to Figure 12 for correct wiring.

It is important to ensure that the sensor shares the **same common** as the M2000 so that there is no 24 VAC feedback sent back to the controller, which can interfere with the controller's ability to maintain accurate analog input readings.

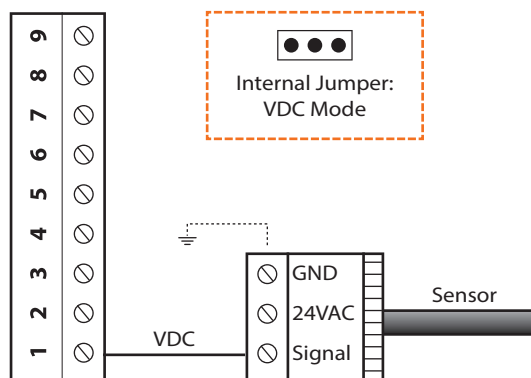

Figure 12 - Connecting a voltage based sensor to analog input 1



Signal: Current

The M2000 FlexIO controller inputs can be used to monitor the current signal produced by a variety of transducers (such as pressure, gas, humidity and more). Please refer to Figure 13 for correct wiring.

It is important to ensure that the sensor shares the **same common** as the M2000 so that there is no 24 VAC feedback sent back to the controller, which can interfere with the controller's ability to maintain accurate analog input readings.

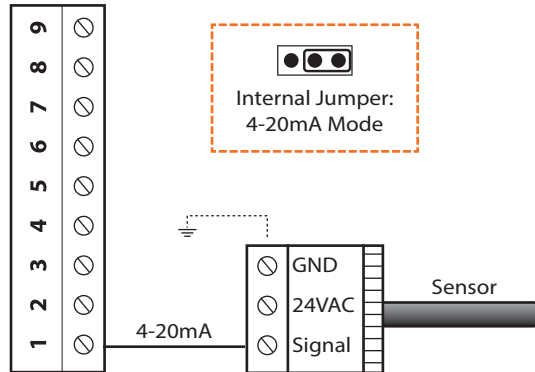

Figure 13 - Connecting a current based sensor to analog input 1



Outputs

The M2000 FlexIO controller contains 8 customizable outputs; five triac ON/OFF outputs (24VAC) and three analog outputs (0-10VDC). Output configuration is performed via the ProLon Focus software.

An integrated resettable fuse protects each of the outputs of the M2000 against current surges and short circuits. This protection will cut the current to the output as soon as an overload condition is detected. The fuse is a round, yellow-coloured PTC that will change to orange and heat up on an overload condition. Once power has been removed from the M2000, the fuse will cool down and automatically reset. Fix the faulty wiring and you will be able to activate the output once again.

Output Specifications

Output	Type	Action
DO 1	Triac source 24VAC, Max Current: 300 mA	On-or-Off / Pulse Width Modulation
DO 2	Triac source 24VAC, Max Current: 300 mA	On-or-Off / Pulse Width Modulation
DO 3	Triac source 24VAC, Max Current: 300 mA	On-or-Off / Pulse Width Modulation
DO 4	Triac source 24VAC, Max Current: 300 mA	On-or-Off / Pulse Width Modulation
DO 5	Triac source 24VAC, Max Current: 300 mA	On-or-Off / Pulse Width Modulation
AO 1	Configurable Analog Output: - 0 to 10 VDC - 2 to 10 VDC - 0 to 5 VDC Max Current: 40 mA	On-or-Off / Pulse Width Modulation / Modulating Proportional
AO 2	Configurable Analog Output: - 0 to 10 VDC - 2 to 10 VDC - 0 to 5 VDC Max Current: 40 mA	On-or-Off / Pulse Width Modulation / Modulating Proportional
AO 3	Configurable Analog Output: - 0 to 10 VDC - 2 to 10 VDC - 0 to 5 VDC Max Current: 40 mA	On-or-Off / Pulse Width Modulation / Modulating Proportional



Typical Connection of Triac Outputs 1 to 5

On the M2000 FlexIO controller, all triac outputs produce a 24 VAC live voltage when activated. Note that all output voltages originate from the same voltage supply that is powering the controller (see Figure 16). Consequentially, only the live side of the output connections are usually needed; these are on the top row (see Figure 14). The bottom row is the common (GND).

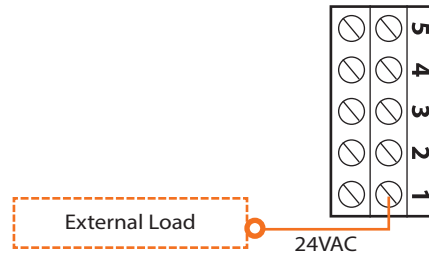

Figure 14 - Wiring example of digital outputs 1

Typical Connection of Analog Outputs 1 to 3

For all analog outputs, the common is found on the bottom row terminal blocks, and the active signals are found on the top row terminal blocks (see Figure 15). The analog outputs can modulate a DC load, work in ON/OFF mode, or use pulse width modulation.

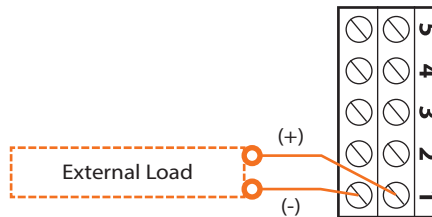

Figure 15 - Wiring example of an analog output 1



Power Source

The M2000 controller is powered by a 24 VAC power supply (class 2) by connecting the common ("C" wire) to the "COM" terminal and the live ("R" wire) to the "24 VAC" terminal (see Figure 16). The common for all inputs and outputs is the same as the power source's common. All output power sources also originate from the source transformer (class 2).

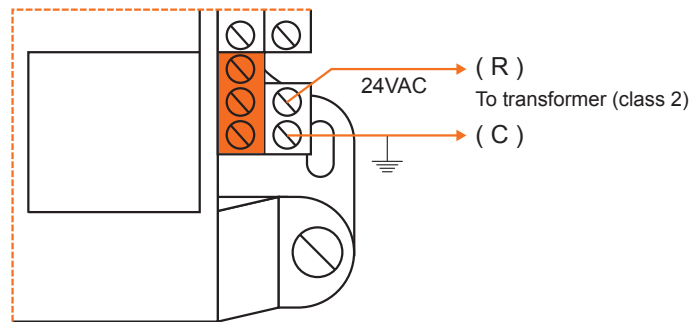

Figure 16 - Connecting the 24VAC power source

Network Communication

The Proton M2000 FlexIO controller is designed to work standalone or networked with Proton controllers. When networked, it can receive the occupancy status, outside air and supply air temperatures in real-time. The network connections are made using the network terminal blocks located on the M2000 controller (see Figure 17).

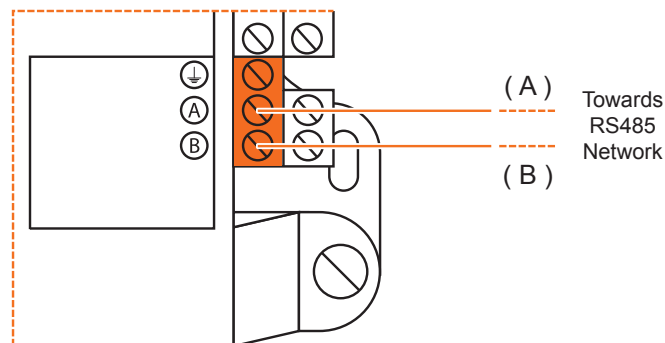

Figure 17 - Connecting to the network



Technical Specifications

Supply: 24 VAC \pm 10%, 50/60 Hz, Class 2

Power: 5 VA (consumption), 40 VA (Input)

Inputs: 9 analog inputs with individually configurable signal ranges (thermistor, dry contact, 4-20mA, 0-5 VDC, 1-5VDC, 0.5-4.5 VDC)

Digital Outputs: 5 triac outputs, 10-30 VAC source, 300 mA max (resettable fuse)

Analog Outputs: 3 x 0-10 VDC outputs, 40 mA max

Indication lights (LED): State of each output / Communication / Power / State of microprocessor

Microprocessor: PIC18F6722, 8 bits, 40 MHz, 128KB FLASH memory

Casing: Molded ABS, UL94-HB

Communication: Modbus RTU (RS485) up to 127 nodes

Baud Rates: 9600, 19200, 38400, 57600, 76800, 115200

Connection: Removable screw-type terminal blocks (max 16 AWG) and RJ45 modular jacks

Dimensions: 5.39" x 4.41" x 2.25" (137 mm x 112 mm x 57 mm)

Weights: 1.05 lbs (0.48 kg)

Environment: -4 to 122 °F (-20 to 50 °C) Non-Condensing

Certification: UL916 Energy Management Equipment, CAN/CSA-C22.2, RoHS, FCC part 15: 2012 class B

The performance specifications are nominal and conform to acceptable industry standards. Prolon Inc. will not be liable for damages resulting from misapplication or misuse of its products.



Compliance

- cULus Listed; UL 916 Energy Management Equipment, File E364757, Vol.1
- CAN/CSA-C22.2 No. 2015-12, Signal Equipment
- FCC Compliant to CFR47, Part 15, Subpart B, Class B
- Industry Canada (IC) Compliant to ICES-003, Issue 5: CAN ICES-3 (B)/NMB-3(B)
- RoHS Directive (2002/95/EC)

FCC User Information

This device complies with Part 15 of the FCC Rules. Operation is subject to the following two conditions: (1) this device may not cause harmful interference, and (2) this device must accept any interference received, including interference that may cause undesired operation.

Caution: Any changes or modifications not approved by Prolon can void the user's authority to operate the equipment.

Note: This equipment has been tested and found to comply with the limits for a Class B digital device, pursuant to part 15 of the FCC Rules. These limits are designed to provide reasonable protection against harmful interference in a residential installation. This equipment generates, uses and can radiate radio frequency energy and, if not installed and used in accordance with the instructions, may cause harmful interference to radio communications. However, there is no guarantee that interference will not occur in a particular installation. If this equipment does cause harmful interference to radio or television reception, which can be determined by turning the equipment off and on, the user is encouraged to try to correct the interference by one or more of the following measures:

- Reorient or relocate the receiving antenna.
- Increase the separation between the equipment and receiver.
- Connect the equipment into an outlet on a circuit different from that to which the receiver is connected.
- Consult the dealer or an experienced radio/TV technician for help.

Industry Canada

This Class (B) digital apparatus meets all the requirements of the Canadian Interference-Causing Equipment regulations.

Cet appareil numérique de la Classe (B) respecte toutes les exigences du Règlement sur le matériel brouilleur du Canada.



Overall Dimensions

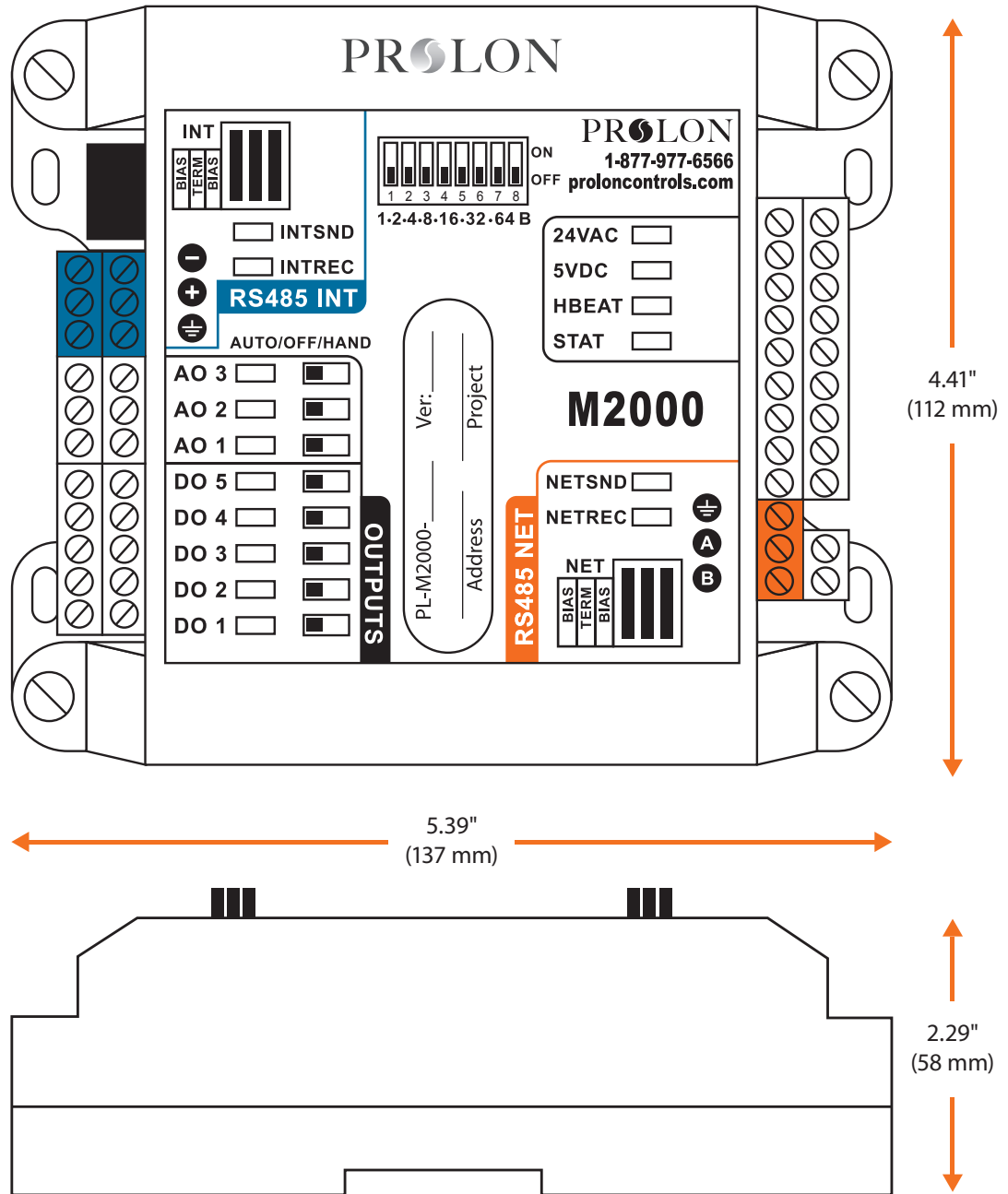

Figure 18 - M2000 Size Diagram

REV. 7.3.1

PL-HRDW-FLX-M2000-EN

© Copyright 2026 Prolon. All rights reserved.

No part of this document may be photocopied or reproduced by any means, or translated to another language without prior written consent of Prolon. All specifications are nominal and may change as design improvements are introduced. Prolon shall not be liable for damages resulting from misapplication or misuse of its products. All trademarks are the property of their respective owners.