



HARDWARE GUIDE

Heatpump Controller M2000 Series

Specifications and Operational Guide

www.proloncontrols.com | info@proloncontrols.com
17 510, rue Charles, Suite 100, Mirabel, QC, J7J 1X9



Table of Contents

General Information	4
PL-M2000 Heatpump Controller	4
Description.....	4
General Behavior	4
Operating Sequence	5
General	5
Occupied Mode.....	5
Unoccupied Mode.....	5
Components	6
Component Identification.....	6
LEDs and Switches.....	7
HAND/OFF/AUTO Switches	8
Jumpers.....	8
Input and Output Identification.....	9
Addressing Dipswitch Configuration for Network Communication.....	10
Inputs	11
Temperature Sensors	11
Room Sensors	12
Proof of Fan.....	12
Dry Contact for Clogged Filter or Schedule Override	13
Dry Contact for Alarm Signal.....	13
Static Pressure and CO ₂	14
Outputs	15
Output Specifications	15
Typical Connection of Triac Outputs 1 to 5.....	16
Typical Connection of Analog Outputs 1 to 3.....	16
Power Source & Network	17
Power Source	17
Network Communication	17
Technical Specifications	18
Compliance	19
FCC User Information	19
Industry Canada	19
Overall Dimensions.....	20



Table of Figures

Figure 1 - Component Identification.....	6
Figure 2 - LEDs Identification	7
Figure 3 - Location of the EXTERNAL jumpers.....	8
Figure 4 - Location of the INTERNAL jumpers.....	8
Figure 5 - INT and NET jumpers	8
Figure 6 - AI jumpers.....	8
Figure 7 - Input and Output Identification.....	9
Figure 8 - RJ45 Pinout.....	9
Figure 9 - Addressing Dipswitch.....	10
Figure 10 - Connecting the Temperature Sensors.....	11
Figure 11 - Typical Wiring of the PL-RS Room Sensor to the Controller.....	12
Figure 12 - Connecting the Proof of Fan Contact to the Controller	12
Figure 13 - Connecting the Dry Contact Input to the Controller	13
Figure 14 - Connecting the Alarm Contact to the Controller	13
Figure 15 - Connecting the CO2 and Pressure Sensors	14
Figure 16 - Connecting of Digital Outputs 3 and 4.....	16
Figure 17 - Connecting Analog Output 1 (External Power)	16
Figure 18 - Connecting the 24VAC Power Source.....	17
Figure 19 - Connecting to the Network.....	17
Figure 20 - M2000 Size Diagram	20



PL-M2000 Heatpump Controller

Description

The Proton PL-M2000 Heatpump controller is a microprocessor-based controller designed to operate residential or commercial heatpump equipment. It uses PI (Proportional-Integral) control loops and acts as a master when used on a network with Proton zone controllers.

The Standalone model of this controller will not act as a master to other Proton zone controllers, relying instead on the demand provided by a local sensor.

General Behavior

Although fully configurable, the Proton M2000 Heatpump controller uses pre-established control sequences or “profiles” to operate specific HVAC equipment with dedicated output functions. These can be fully optimized to obtain the best results for each type of system. Numerous parameters enable the modification or fine tuning of the fan, the compressor outputs, the action of the heating outputs (On-or-Off / pulsed / modulating), the bypass or VFD, outside air dampers, CO2 levels, the proportional bands, integration times, differentials, operational ranges, setpoints and a whole range of limits and safeguards. The various programming options also allow the user to modify the schedule, unoccupied mode settings, morning warm-up and supply air pre-heating sequences as well as the network demand control strategy best suited for the building space it is controlling. All these parameters can be accessed by using the Proton Focus software.

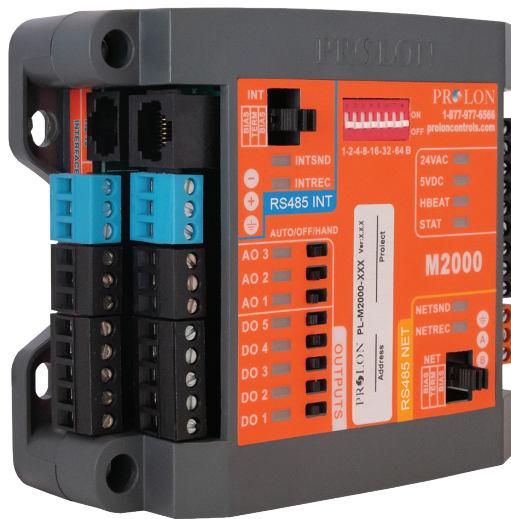



Operating Sequence

General

The Proton M2000 Heatpump controller receives readings from three different temperature sensors: outside air, return air and supply air. It operates on a configurable schedule using an internal real-time clock. Also, as a Master device, it receives data from the zone controllers sent on the network bus. The controller then analyzes all the data and demands sent by the zones and commands the appropriate outputs to respond accordingly, within parameters set by the temperature sensors and other safety limits. The Master sends back information on its network such as supply air temperature, occupancy status and other relevant data for the zone controllers to use.

Occupied Mode

The controller operates the fan. When there is a cooling demand from the zones, the Heatpump controller will put the reversing valve into cooling mode and activate the compressor outputs as long as all temperature limits, delays and other related parameters are respected. Once the demand is satisfied, the outputs are deactivated within the prescribed minimum on/off time delays.

When there is a heating demand from the zones and the outside temperature is above the low balance point, the Heatpump controller will put the reversing valve into heating mode and activate the compressor outputs as long as all temperature limits, delays and other related parameters are respected. If the outside temperature is below the low balance point, the controller will activate the auxiliary heating outputs. If the heatpump is configured for water-to-air mode, the low balance point is ignored and the use of compressors is permitted all year round. Protection sequences are in place that will activate auxiliary heat upon failure of the compressors. Once the demand is satisfied, the outputs are deactivated within the prescribed minimum on/off time delays.

When there is no cooling or heating demand from the zones, only the fan is enabled. If the heating equipment permits, a supply air pre-heating sequence may be enabled. This allows cold mixed air to be heated to a more comfortable level for subsequent use by the zones for ventilation.

Unoccupied Mode

The fan can be configured to operate in intermittent mode. When there is a cooling or heating demand from any single zone, the Rooftop controller will activate the fan and the necessary cooling or heating outputs as long as all temperature limits, delays and other related parameter are respected. Once the demand is satisfied, the fan and any cooling/heating outputs are deactivated within the minimum on/off time delays set.

During the unoccupied period, the Rooftop controller can be driven by the highest demand on the network and will operate the fan and relevant outputs accordingly.



Component Identification

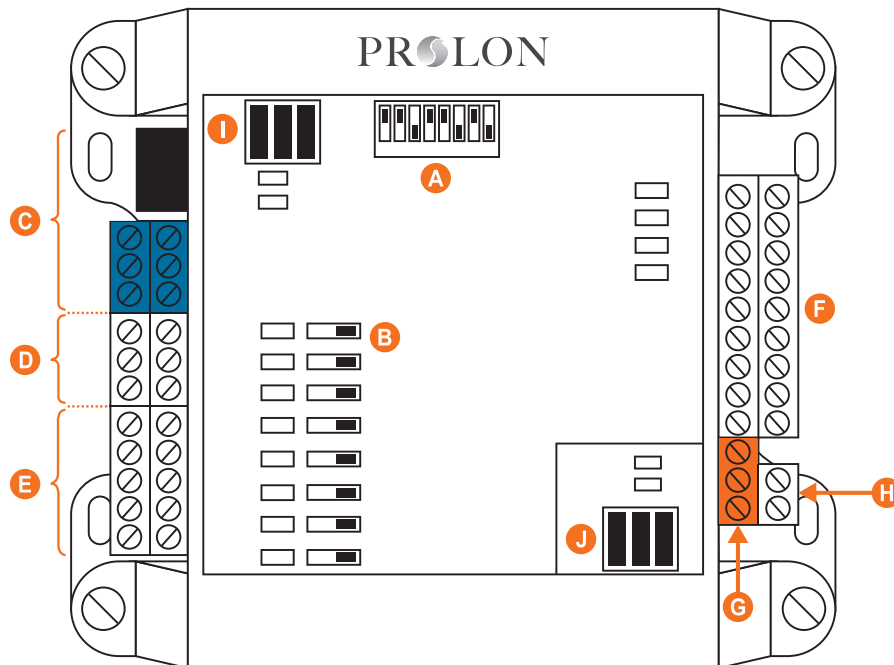

Figure 1 - Component Identification

Legend:

- A - Addressing Dipswitch
- B - AUTO/OFF/HAND Switches
- C - RS485 INT port for interface communication (RJ45 plug and screw connectors are in parallel)
- D - Analog outputs (3)
- E - Digital outputs (5)
- F - Analog inputs (9)
- G - RS485 NET port for network communication
- H - Terminal block for 24VAC (Class 2 transformer)
- I - Jumpers for terminating and bias resistors for the INT port
- J - Jumpers for terminating and bias resistors for the NET port



LEDs and Switches

The M2000 has various LEDs which are linked to different functions and outputs of the controller. Each LED is individually identified to help the user make a quick visual diagnostic of the controller's activity and status.

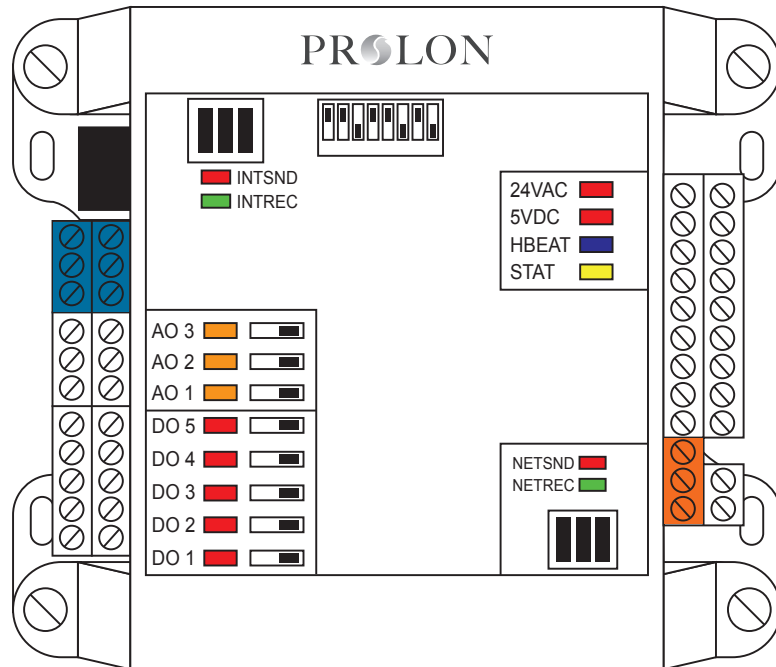

Figure 2 - LEDs Identification

LED Descriptions

- **24 VAC:** The M2000 is receiving 24 VAC from the power source.
- **5V DC:** The microchip and other components on the M2000 are being powered successfully by a 5VDC source derived from the 24VAC source.
- **HBEAT:** When this LED is blinking, the microchip is active and the controller's program is running (normal). When this LED is ON and steady, the M2000 is inactive and the microchip is awaiting programming (you must use Prolon's Focus software to reprogram the microchip).
- **STAT:** Reserved.
- **NETSND:** Indicates the transmission of data onto the network communication bus.
- **NETREC:** Indicates reception of data from the network communication bus.
- **INTSND:** Indicates the transmission of data onto the interface communication bus.
- **INTREC:** Indicates the reception of data from the interface communication bus.
- **AO3:** The intensity of the LED represents the voltage present on analog output 3.
- **AO2:** The intensity of the LED represents the voltage present on analog output 2.
- **AO1:** The intensity of the LED represents the voltage present on analog output 1.
- **DO5:** Represents the activity of digital output 5.
- **DO4:** Represents the activity of digital output 4.
- **DO3:** Represents the activity of digital output 3.
- **DO2:** Represents the activity of digital output 2.
- **DO1:** Represents the activity of digital output 1.



HAND/OFF/AUTO Switches

Each output on the M2000 has a dedicated switch that lets the user manually override the activity of the output. “HAND” mode (switch at rightmost position) fully activates the output (24 VAC for digital outputs, 10VDC for analog outputs). “OFF” (switch at center) deactivates the output and “AUTO” (switch at left) returns control of the output to the program in the M2000’s microchip.

Jumpers

The M2000 has jumpers that are externally accessible (see Figure 3), as well as jumpers that are inside the controller on the top internal board (see Figure 4), that allow for configuration of various hardware elements.

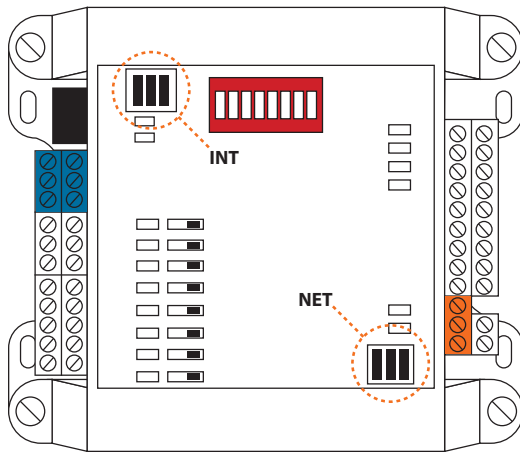

Figure 3 - Location of the EXTERNAL jumpers

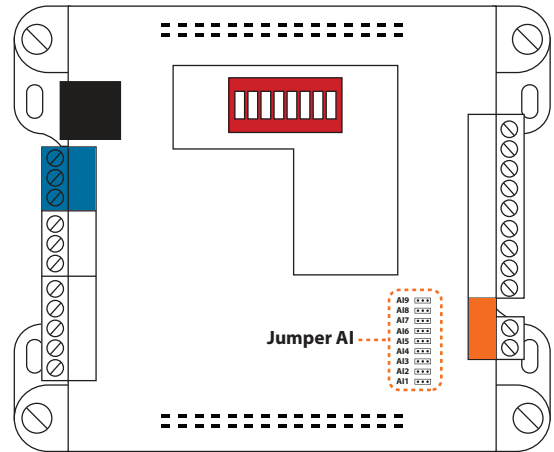

Figure 4 - Location of the INTERNAL jumpers

- **INT:** These are the jumpers for the bias and terminating resistors used for the interface communication bus. See the Proton network guide for information about bias and terminating resistors. (See Figure 5)
- **NET:** These are the jumpers for the bias and terminating resistors used for the network communication bus. See the Proton network guide for information about bias and terminating resistors. (See Figure 5)
- **AI 1 - 9:** These jumpers allow the user to select the signal mode of the associated analog input. (See Figure 6)

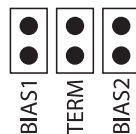

Figure 5 - INT and NET jumpers



Figure 6 - AI jumpers



Input and Output Identification

All the inputs and outputs of the M2000 use pluggable screw type terminal blocks with elevator style clamping, which make connections easier and more secure.

For incoming communication from a remote computer or network controller, dual RJ45 type connectors are available **in parallel** with screw type terminal blocks. The RJ45 connectors allow the use of premade CAT5 cables for simple plug-and-play RS485 communication. These RJ45 connectors follow the Modbus pinout specification for RS485 communication.

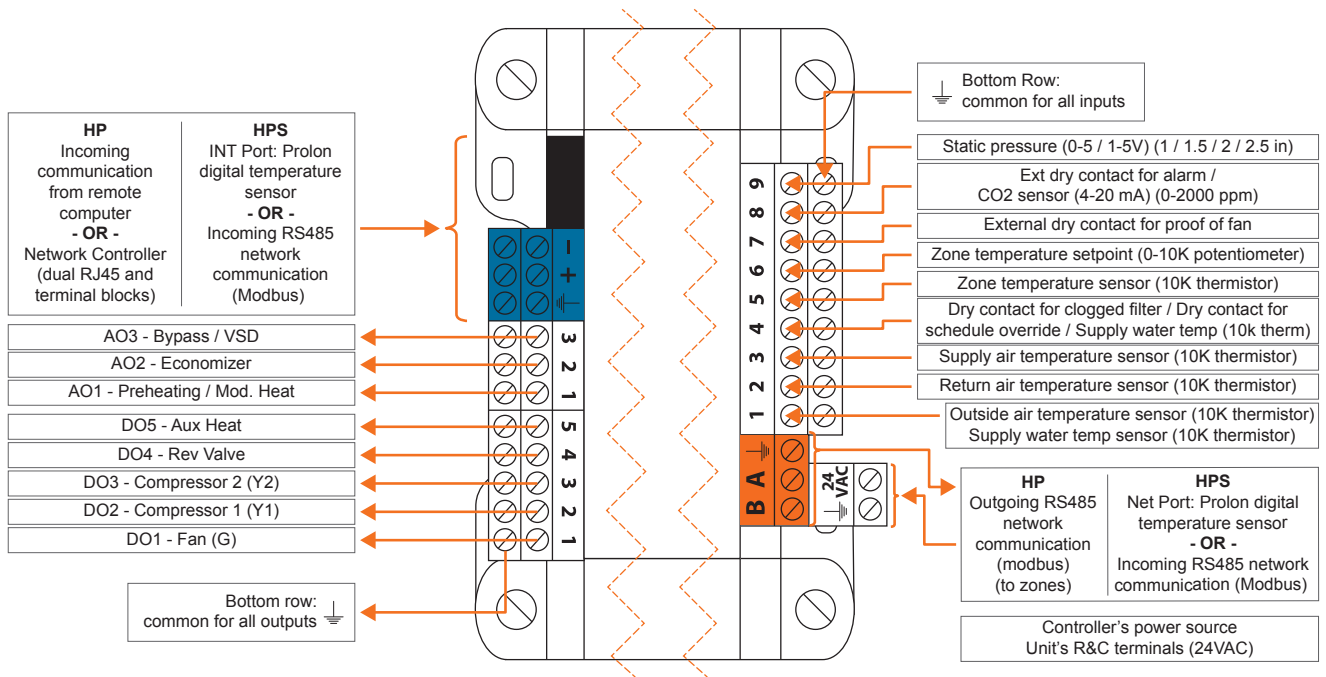

Figure 7 - Input and Output Identification

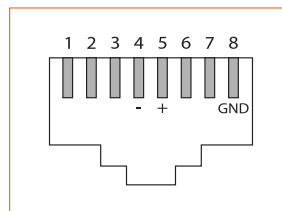

Figure 8 - RJ45 Pinout



Addressing Dipswitch Configuration for Network Communication

For proper communication, a unique address must be configured on each controller by setting the first 7 switches on the addressing dipswitch to the desired value.

These switches are numbered from 1 to 7 and represent a binary value from 1 to 64 (1, 2, 4, 8, 16, 32, and 64 respectively). The last switch (#8) is reserved. The value of each switch that is in the ON position is added together to form the numerical address of the controller.

The example in Figure 9 shows the switches 1, 2 and 4 in the ON position. Therefore, the corresponding values are 1, 2 and 8, giving an address sum of 11.

The Proton network allows a maximum of 127 addresses; therefore 127 controllers.

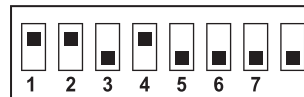

Figure 9 - Addressing Dipswitch



Temperature Sensors

The M2000 Heatpump controller has analog inputs that can monitor supply and return air temperatures, as well as another that can monitor either the outside air or supply water temperature (water-to-air mode only, see figure 10) and will integrate these readings into its control sequence.

Alternatively, the supply air temperature can be retrieved from a zone controller that has its own supply sensor and belongs to the M2000's network.

The outside air temperature can be also be provided by an alternate source. If a network controller is present on the network, it can retrieve the outside temperature reading from one controller and distribute it to any other controllers on the network.

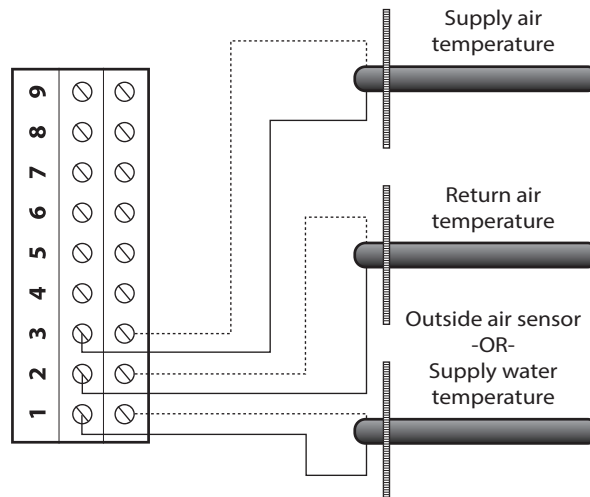

Figure 10 - Connecting the Temperature Sensors



Room Sensors

The M2000 can receive the setpoint and temperature from a specific room when a PL-RS analog thermostat is connected to it. The M2000 will then automatically integrate this information into its control sequence. The setpoint may also simply be set by software. The PL-RS series room sensors are connected using a 3-conductor cable (see Figure 11).

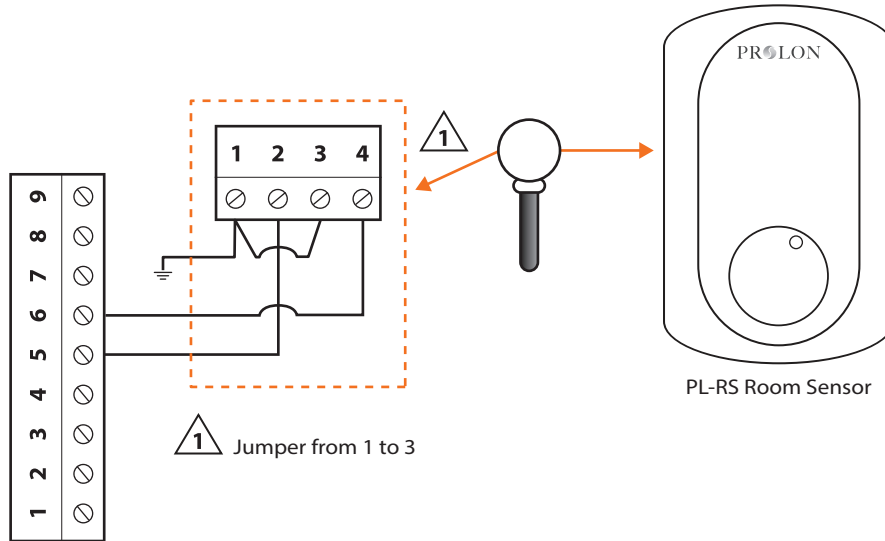

Figure 11 - Typical Wiring of the PL-RS Room Sensor to the Controller

Proof of Fan

The M2000 has an analog input dedicated to the proof of fan signal. Please refer to Figure 12 to see how to correctly connect it to analog input 7. To indicate proof of fan, the contact must be closed. If no proof of fan signal is available, you must short analog input 7, or else the controller will interpret the absence of signal as a fan malfunction and no heating or cooling action will be taken.

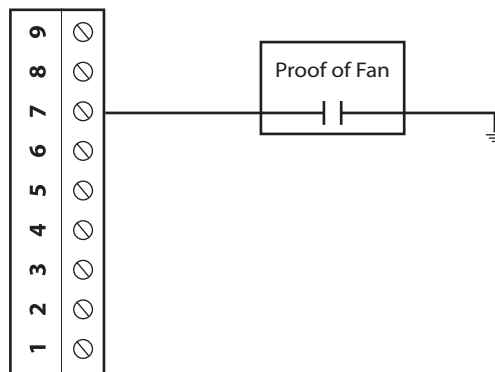

Figure 12 - Connecting the Proof of Fan Contact to the Controller



Dry Contact for Clogged Filter or Schedule Override

Analog input 4 on the M2000 can also be configured as a dry contact input for either a clogged filter sensor or as a schedule override input. Please refer to Figure 13 to see proper connection.

- **Clogged filter sensor:** To indicate that the filter is clogged, the contact must be closed.
- **Schedule Override:** Closing the contact causes the M2000 to immediately return to occupied mode from unoccupied mode. The M2000 remains in occupied mode as long as the contact is held closed. If it was already in occupied mode, there is no change.

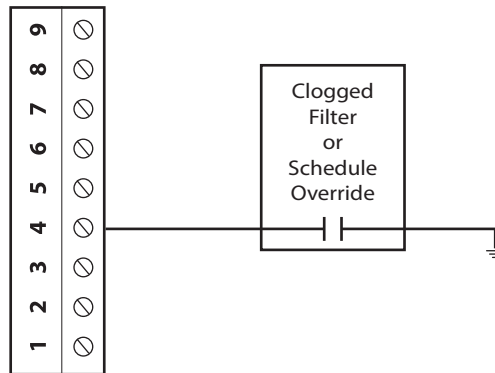

Figure 13 - Connecting the Dry Contact Input to the Controller

Dry Contact for Alarm Signal

The M2000 has an analog input which can be designated as an alarm signal input. Please refer to Figure 14 to see how to correctly connect it to analog input 8. To signal an alarm, the contact must be closed. Closing this contact will prevent the use of the compressors, either in heating or cooling. Auxiliary heating will still activate as required.

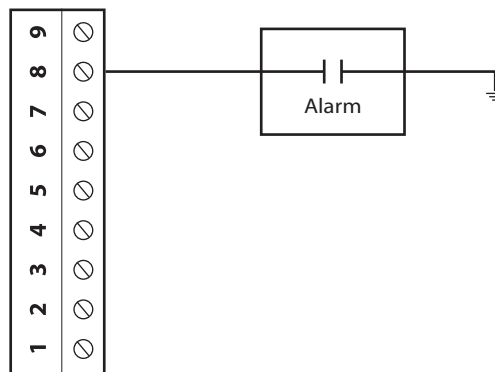

Figure 14 - Connecting the Alarm Contact to the Controller



Static Pressure and CO₂

Analog inputs 8 and 9 on the M2000 heatpump controller are dedicated to the CO₂ and static pressure sensors, respectively. By default, a 4-20 mA signal is expected for the CO₂ input and a 0-5 VDC or 1-5 VDC signal is expected for the static pressure input. However, this can be modified using the internal jumpers (see p.8). Please refer to Figure 15 for correct wiring.

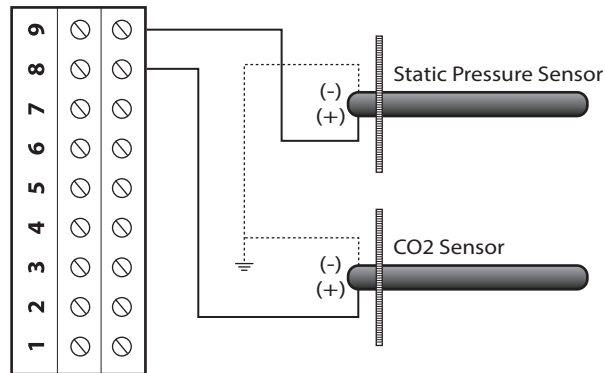

Figure 15 - Connecting the CO₂ and Pressure Sensors



Outputs

The M2000 Heatpump controller contains 8 customizable outputs; five triac ON/OFF outputs (24VAC) and three analog outputs (0-10VDC). Output configuration is performed via the Proton Focus software.

An integrated resettable fuse protects each of the outputs of the M2000 against current surges and short circuits. This protection will cut the current to the output as soon as an overload condition is detected. The fuse is a round, yellow-coloured PTC that will change to orange and heat up on an overload condition. Once power has been removed from the M2000, the fuse will cool down and automatically reset. Fix the faulty wiring and you will be able to activate the output once again.

Output Specifications

Output	Type	Action	Application
DO 1	Triac source 24VAC, Max Current: 300 mA	On-or-Off	Fan (G)
DO 2	Triac source 24VAC, Max Current: 300 mA	On-or-Off	Compressor (1st Stage) (Y1)
DO 3	Triac source 24VAC, Max Current: 300 mA	On-or-Off	Compressor (2nd Stage) (Y2)
DO 4	Triac source 24VAC, Max Current: 300 mA	On-or-Off	Reversing Valve
DO 5	Triac source 24VAC, Max Current: 300 mA	On-or-Off	Auxiliary Heat
AO 1	Configurable Analog Output: - 0 to 10 VDC - 2 to 10 VDC - 0 to 5 VDC Max Current: 40 mA	Modulating Proportional/ Plused/ On-or-Off	Preheating Only/ Preheat + Heating/ Heating
AO 2	Configurable Analog Output: - 0 to 10 VDC - 2 to 10 VDC Max Current: 40 mA	Modulating Proportional	Economizer
AO 3	Configurable Analog Output: - 0 to 10 VDC - 2 to 10 VDC Max Current: 40 mA	Modulating Proportional	Bypass/ Variable Frequency Drive



Typical Connection of Triac Outputs 1 to 5

On the M2000 Heatpump controller, all triac outputs produce a 24 VAC live voltage when activated. Note that all output voltages originate from a single voltage supply: the equipment's transformer. Consequentially, only the live side of the output connections are usually needed; these are on the top row (see figure 16). The bottom row is the common (GND).

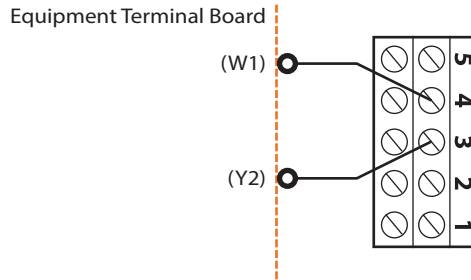

Figure 16 - Connecting of Digital Outputs 3 and 4

Typical Connection of Analog Outputs 1 to 3

For all analog outputs, the common is found on the bottom row terminal blocks, and the active signals are found on the top row terminal blocks (see Figure 17). Analog outputs 1 can be configured to modulate a 0-10 VDC load, to pulse a 0 or 10 VDC triac relay or to control a 10 VDC On/Off relay. Analog outputs 2 and 3 can only modulate a DC load (0-10 VDC or 2-10 VDC).

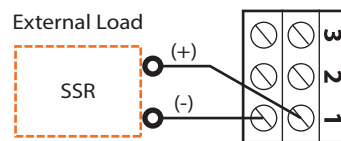

Figure 17 - Connecting Analog Output 1 (External Power)



Power Source & Network

Power Source

The M2000 controller is powered by the HVAC equipment's 24 VAC Class 2 power supply by connecting the common ("C" wire) to the "COM" terminal block and the live ("R" wire) to the "24 VAC" terminal block (see Figure 18). The common for all inputs and outputs is the same as the power source's common. All output power sources also originate from the HVAC equipment's power source.

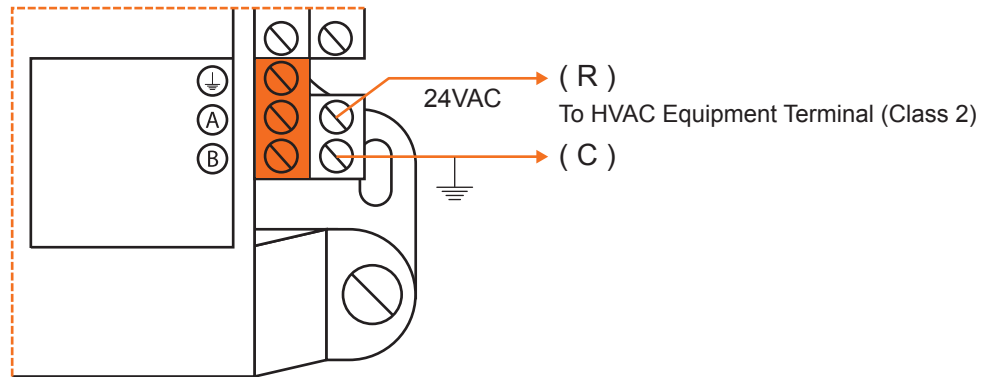

Figure 18 - Connecting the 24VAC Power Source

Network Communication

The Proton M2000 Heatpump controller is designed to work with the Proton zone controllers (except Heatpump Standalone controller). When they are networked, the M2000 and zone controllers all communicate in real-time. The network connections are made using the network terminal block located on the M2000 controller (see Figure 19).

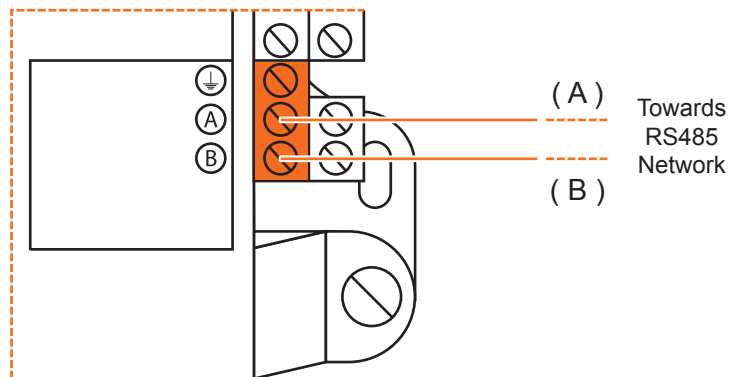

Figure 19 - Connecting to the Network



Technical Specifications

Supply: 24 VAC \pm 10%, 50/60 Hz, Class 2

Power: 5 VA (consumption), 40 VA (Input)

Inputs: 9 configurable analog inputs (thermistor / dry contact / 4-20mA / 0-5 VDC)

Digital Outputs: 9 configurable analog inputs (outside temperature / return / supply / zone / water supply / dry contact for clogged filter / schedule override / proof of fan / alarm, room setpoint, static pressure). Input signals (thermistor / dry contact / 4-20mA / 0-5 VDC) individually configurable for each input

Analog Outputs: 3 x 0-10 VDC outputs, 40 mA max

Indication lights (LED): State of each output / Communication / Power / State of microprocessor

Microprocessor: PIC18F6722, 8 bits, 40 MHz, 128KB FLASH memory

Communication (HP): Modbus RTU (RS485) or BACnet MS/TP (RS485), up to 127 nodes

Communication (HPS): Modbus RTU (RS485), up to 127 nodes

Baud Rates: 9600, 19200, 38400, 57600, 76800, 115200

Connection: Removable screw-type terminal blocks (max 16 AWG) and RJ45 modular jacks

Dimensions: 5.39" x 4.41" x 2.25" (137 mm x 112 mm x 57 mm)

Weights: 1.05 lbs (0.48 kg)

Environment: -4 to 122 °F (-20 to 50 °C) Non-Condensing

Certification: UL916 Energy Management Equipment, CAN/CSA-C22.2, RoHS, FCC part 15: 2012 class B

The performance specifications are nominal and conform to acceptable industry standards. Prolon Inc. will not be liable for damages resulting from misapplication or misuse of its products.



Compliance

- cULus Listed; UL 916 Energy Management Equipment, File E364757, Vol.1
- CAN/CSA-C22.2 No. 2015-12, Signal Equipment
- FCC Compliant to CFR47, Part 15, Subpart B, Class B
- Industry Canada (IC) Compliant to ICES-003, Issue 5: CAN ICES-3 (B)/NMB-3(B)
- RoHS Directive (2002/95/EC)

FCC User Information

This device complies with Part 15 of the FCC Rules. Operation is subject to the following two conditions: (1) this device may not cause harmful interference, and (2) this device must accept any interference received, including interference that may cause undesired operation.

Caution: Any changes or modifications not approved by Prolon can void the user's authority to operate the equipment.

Note: This equipment has been tested and found to comply with the limits for a Class B digital device, pursuant to part 15 of the FCC Rules. These limits are designed to provide reasonable protection against harmful interference in a residential installation. This equipment generates, uses and can radiate radio frequency energy and, if not installed and used in accordance with the instructions, may cause harmful interference to radio communications. However, there is no guarantee that interference will not occur in a particular installation. If this equipment does cause harmful interference to radio or television reception, which can be determined by turning the equipment off and on, the user is encouraged to try to correct the interference by one or more of the following measures:

- Reorient or relocate the receiving antenna.
- Increase the separation between the equipment and receiver.
- Connect the equipment into an outlet on a circuit different from that to which the receiver is connected.
- Consult the dealer or an experienced radio/TV technician for help.

Industry Canada

This Class (B) digital apparatus meets all the requirements of the Canadian Interference-Causing Equipment regulations.

Cet appareil numérique de la Classe (B) respecte toutes les exigences du Règlement sur le matériel brouilleur du Canada.



Overall Dimensions

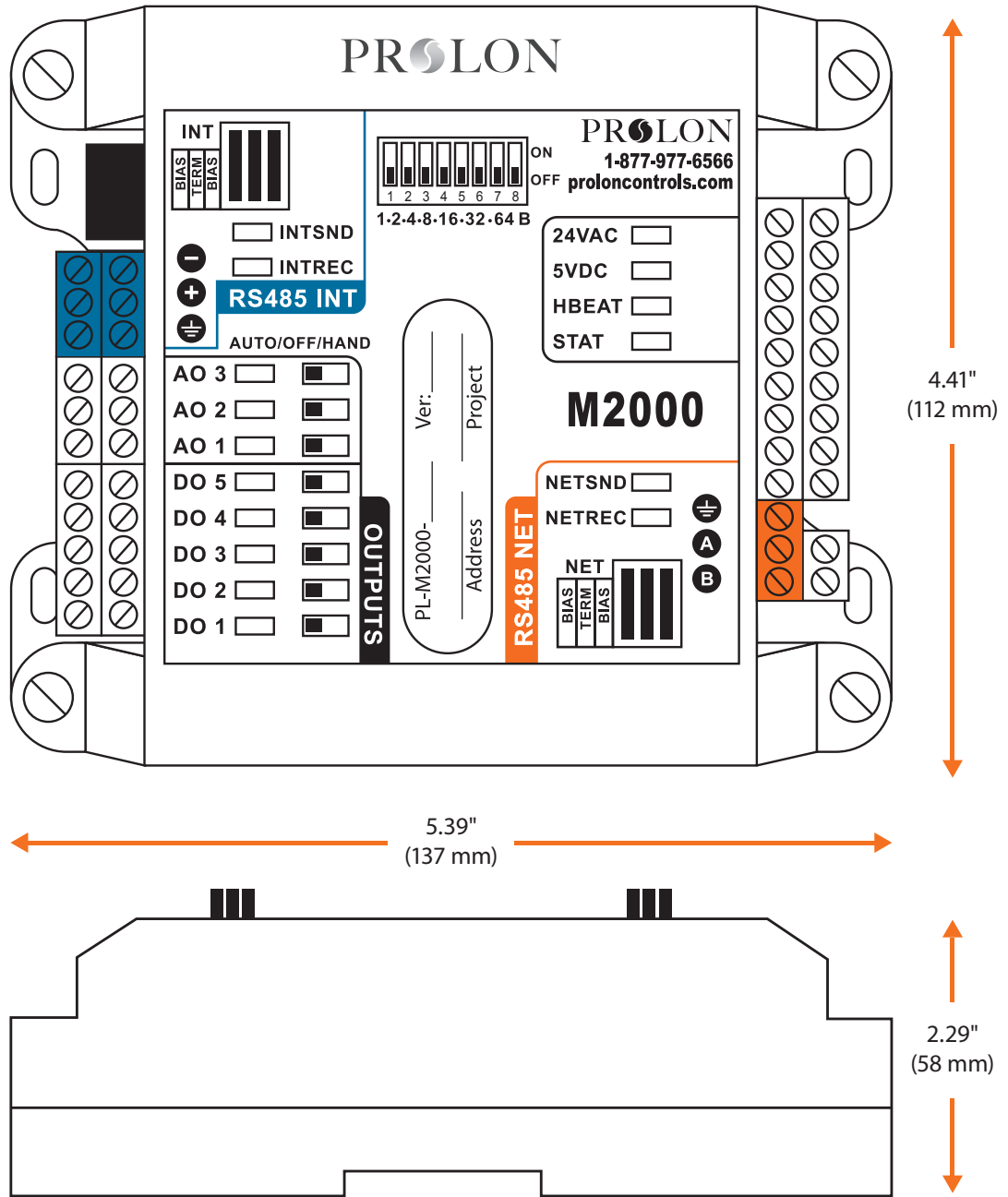

Figure 20 - M2000 Size Diagram

REV. 7.3.2

PL-HRDW-HP-M2000-C/F-EN

© Copyright 2026 Prolon. All rights reserved.

No part of this document may be photocopied or reproduced by any means, or translated to another language without prior written consent of Prolon. All specifications are nominal and may change as design improvements are introduced. Prolon shall not be liable for damages resulting from misapplication or misuse of its products. All trademarks are the property of their respective owners.