



# HARDWARE GUIDE

## Air Make Up Controller M2000 Series

---

Specifications and Operational Guide

---

[www.proloncontrols.com](http://www.proloncontrols.com) | [info@proloncontrols.com](mailto:info@proloncontrols.com)  
17 510, rue Charles, Suite 100, Mirabel, QC, J7J 1X9



# Table of Contents

<b>General Information .....</b>	<b>4</b>
PL-M2000 Air Make Up Controller .....	4
Description.....	4
General Behavior .....	4
Operating Sequence .....	5
General .....	5
Summer Sequence.....	5
Winter Sequence .....	5
Mid-Season Sequence .....	5
<b>Components .....</b>	<b>6</b>
Component Identification.....	6
LEDs and Switches.....	7
HAND/OFF/AUTO Switches .....	8
Jumpers.....	8
Input and Output Identification.....	9
Addressing Dipswitch Configuration for Network Communication.....	10
<b>Inputs .....</b>	<b>11</b>
Temperature Sensors .....	11
Building Pressure or CO2.....	11
Proof of Action.....	12
Manual Reset.....	12
<b>Outputs .....</b>	<b>13</b>
Output Specifications .....	13
Typical Connection of Triac Outputs 1 to 5.....	14
Typical Connection of Analog Outputs 1 to 3.....	14
<b>Power Source &amp; Network .....</b>	<b>15</b>
Power Source .....	15
Network Communication .....	15
<b>Technical Specifications .....</b>	<b>16</b>
<b>Compliance .....</b>	<b>17</b>
FCC User Information .....	17
Industry Canada .....	17
<b>Overall Dimensions.....</b>	<b>18</b>



## Table of Figures

Figure 1 - Component Identification.....	6
Figure 2 - LEDs Identification .....	7
Figure 3 - Location of the EXTERNAL jumpers.....	8
Figure 4 - Location of the INTERNAL jumpers.....	8
Figure 5 - INT and NET jumpers .....	8
Figure 6 - AI jumpers.....	8
Figure 7 - Input and Output Identification.....	9
Figure 8 - RJ45 Pinout .....	9
Figure 9 - Addressing Dipswitch.....	10
Figure 10 - Connecting the Temperature Sensors.....	11
Figure 11 - Connecting the CO2 and Pressure Sensors.....	11
Figure 12 - Connecting the Proof of Action Contacts to the Controller.....	12
Figure 13 - Connecting the Manual Reset Contact to the Controller .....	12
Figure 14 - Wiring Example of Digital Outputs 1 and 2.....	14
Figure 15 - Wiring Example of Analog Output 1 .....	14
Figure 16 - Connecting the 24VAC Power Source.....	15
Figure 17 - Connecting to the Network.....	15
Figure 18 - M2000 Size Diagram .....	18



### PL-M2000 Air Make Up Controller

#### Description

The Proton PL-M2000 Air Make Up controller is a microprocessor-based controller designed to operate a variety of different make-up air units and systems. It features a variety of control strategies, including outdoor temperature reset, building pressure control, CO2 control, safety limits and more.

#### General Behavior

Although fully configurable, the Proton M2000 Air Make Up controller monitors dedicated inputs and uses pre-established control sequences to drive dedicated outputs to control standard Make Up Air equipment. These sequences can be fully optimized to obtain the best results for each type of system. Numerous parameters enable the modification or fine tuning of the summer and winter sequences, lockout mode, building pressure and CO2 control, the target supply temperature, the proportional bands, integration times, differentials, operational ranges, setpoints and a whole range of limits and safeguards. All these parameters can be accessed and modified by using the Proton Focus software.

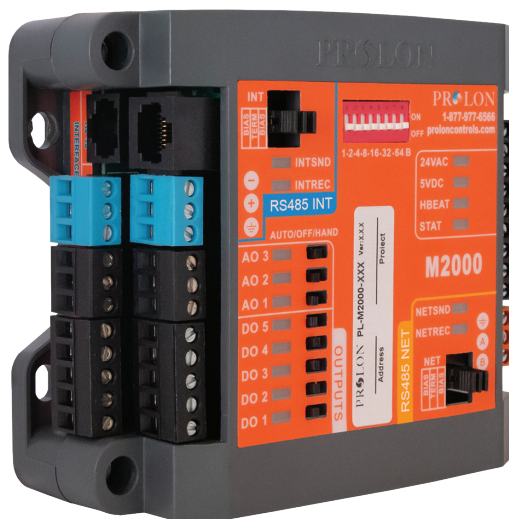



## Operating Sequence

### General

The Proton M2000 Air Make Up controller follows a strict activation sequence before heating or cooling actions can be taken. The sequence begins with the exhaust fan. When proof of exhaust fan is obtained, the outside air damper is opened. When proof of damper opening is obtained, the fan is activated. Finally, when proof of fan is obtained, heating or cooling action is authorized.

Heating and cooling action is decided based on the seasonal sequences defined below.

The controller continuously monitors the inputs and will activate or deactivate the appropriate outputs accordingly, within parameters set by the temperature sensors and other safety limits. Under specific circumstances, the controller will enter Lockout mode, wherein all outputs are deactivated (except the exhaust output). Lockout mode is typically activated when proof of fan or damper is not obtained, or if the supply air low limit is triggered to frequently. To escape lockout mode, a user must press and hold the manual reset button for 3 seconds.

### Summer Sequence

The summer sequence is activated when the outside temperature is above a configurable setpoint. When a proof of fan signal is obtained, cooling action is authorized.

Cooling action can be in the form of a single cooling stage, of dual cooling stages, or of a single analog signal for modulating control to reach a target supply setpoint. Cooling action can either be based on zone demand or on the current outside temperature.

When staged cooling action is demand-based, stages are first authorized based on outside temperature, and then activated when there is sufficient demand. When analog cooling action is demand-based, a supply reset scale is available for configuration in the Proton Focus software. In both these cases, demand is generated by a PI (proportional/integral) loop based on current zone temperature versus current zone setpoints.

When staged cooling action is based on outside temperature, the cooling stages will activate and deactivate based on configurable outside temperature setpoints. When analog cooling action is based on outside temperature, a supply reset scale is available for configuration in the Proton Focus software.

### Winter Sequence

The winter sequence is activated when the outside temperature is below a configurable setpoint. When a proof of fan signal is obtained, the heating authorization output is activated.

Heating action comes in the form of modulating heating which aims to reach a target supply setpoint. The supply setpoint can either be based on zone demand or on the current outside temperature.

When target supply setpoint is demand-based, a supply reset scale is available for configuration in the Proton Focus software. Demand is generated by a PI (proportional/integral) loop based on current zone temperature versus current zone setpoints.

When target supply setpoint is based on outside temperature, a supply reset scale is available for configuration in the Proton Focus software.

### Mid-Season Sequence

The mid-season sequence is activated when the outside temperature is in-between the configurable activation setpoints of the winter and summer sequences. In this sequence, no heating or cooling actions are taken. Only ventilation occurs. The heating authorization output is also off.



## Component Identification

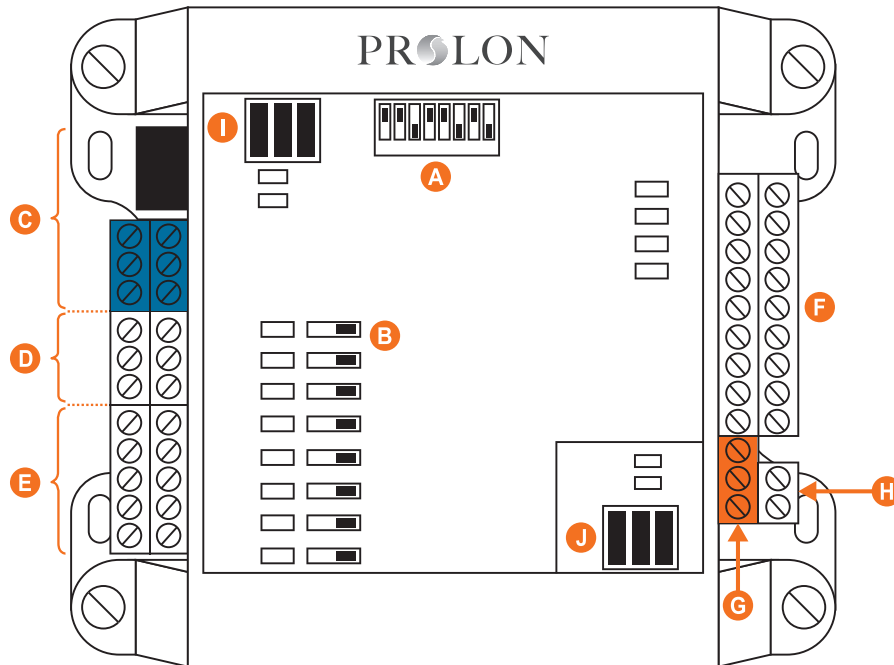

Figure 1 - Component Identification

### Legend:

- A - Addressing Dipswitch
- B - AUTO/OFF/HAND Switches
- C - RS485 INT port for interface communication (RJ45 plug and screw connectors are in parallel)
- D - Analog outputs (3)
- E - Digital outputs (5)
- F - Analog inputs (9)
- G - RS485 NET port for network communication
- H - Terminal block for 24VAC (Class 2 transformer)
- I - Jumpers for terminating and bias resistors for the INT port
- J - Jumpers for terminating and bias resistors for the NET port



## LEDs and Switches

The M2000 has various LEDs which are linked to different functions and outputs of the controller. Each LED is individually identified to help the user make a quick visual diagnostic of the controller's activity and status.

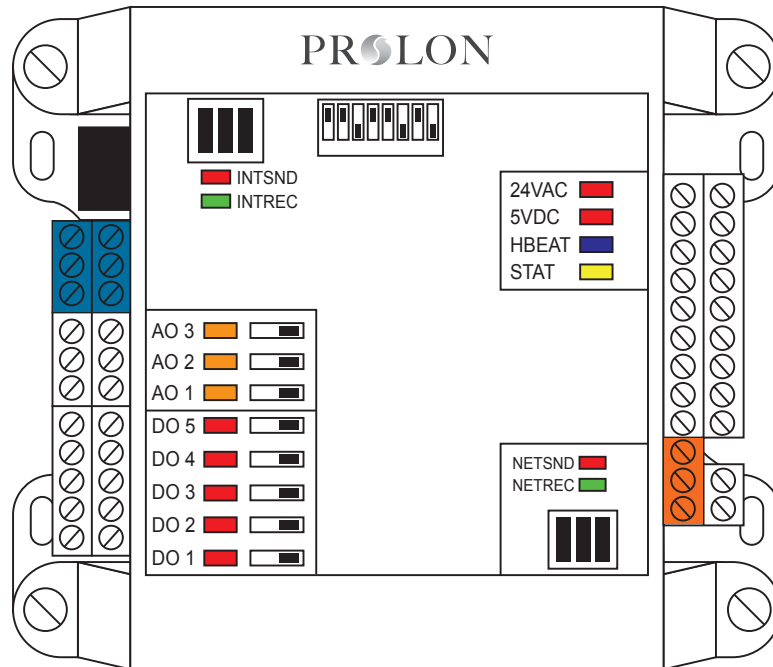

Figure 2 - LEDs Identification

### LED Descriptions

- **24 VAC:** The M2000 is receiving 24 VAC from the power source.
- **5V DC:** The microchip and other components on the M2000 are being powered successfully by a 5 VDC source derived from the 24VAC source.
- **HBEAT:** When this LED is blinking, the microchip is active and the controller's program is running (normal). When this LED is ON and steady, the M2000 is inactive and the microchip is awaiting programming (you must use Prolon's Focus software to reprogram the microchip).
- **STAT:** Reserved.
- **NETSND:** Indicates the transmission of data onto the network communication bus.
- **NETREC:** Indicates reception of data from the network communication bus.
- **INTSND:** Indicates the transmission of data onto the interface communication bus.
- **INTREC:** Indicates the reception of data from the interface communication bus.
- **AO3:** The intensity of the LED represents the voltage present on analog output 3.
- **AO2:** The intensity of the LED represents the voltage present on analog output 2.
- **AO1:** The intensity of the LED represents the voltage present on analog output 1.
- **DO5:** Represents the activity of digital output 5.
- **DO4:** Represents the activity of digital output 4.
- **DO3:** Represents the activity of digital output 3.
- **DO2:** Represents the activity of digital output 2.
- **DO1:** Represents the activity of digital output 1.



## HAND/OFF/AUTO Switches

Each output on the M2000 has a dedicated switch that lets the user manually override the activity of the output. “HAND” mode (switch at rightmost position) fully activates the output (24 VAC for digital outputs, 10VDC for analog outputs). “OFF” (switch at center) deactivates the output and “AUTO” (switch at left) returns control of the output to the program in the M2000’s microchip.

## Jumpers

The M2000 has jumpers that are externally accessible (see Figure 3), as well as jumpers that are inside the controller on the top internal board (see Figure 4), that allow for configuration of various hardware elements.

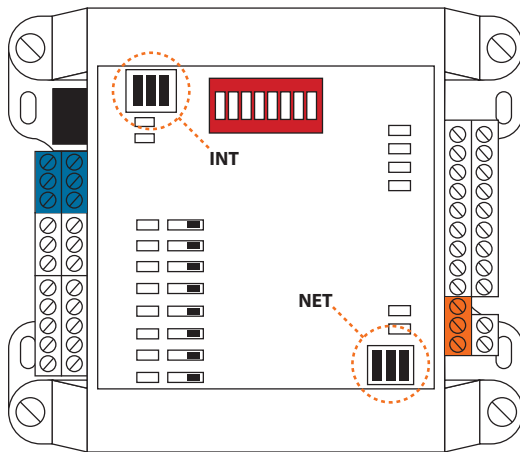

Figure 3 - Location of the EXTERNAL jumpers

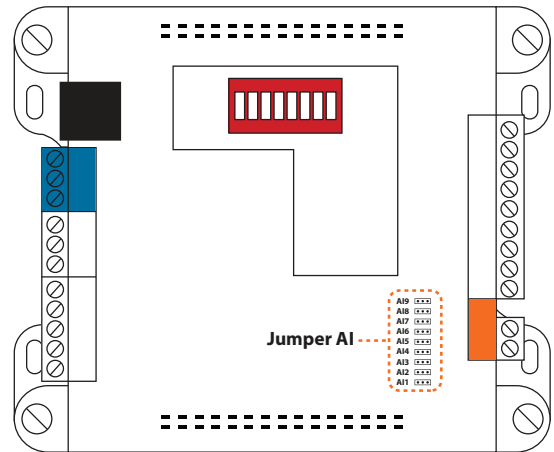

Figure 4 - Location of the INTERNAL jumpers

- **INT:** These are the jumpers for the bias and terminating resistors used for the interface communication bus. See the Proton network guide for information about bias and terminating resistors. (See Figure 5)
- **NET:** These are the jumpers for the bias and terminating resistors used for the network communication bus. See the Proton network guide for information about bias and terminating resistors. (See Figure 5)
- **AI 1 - 9:** These jumpers allow the user to select the signal mode of the associated analog input. (See Figure 6)

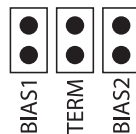

Figure 5 - INT and NET jumpers



Figure 6 - AI jumpers



## Input and Output Identification

All the inputs and outputs of the M2000 use pluggable screw type terminal blocks with elevator style clamping, which make connections easier and more secure.

The M2000 Air Make Up Controller has 2 separate communication ports offering the same functionality on each. Both act as ports for incoming Modbus communications from other Proton devices or interfaces, such as a Network Controller or remote computer with Proton Focus software.

The "INT" Port (see below) offers dual RJ45 type connectors **in parallel** with screw type terminal blocks. The RJ45 connectors allow the use of premade CAT5 cables for simple plug-and-play RS485 communication. These RJ45 connectors follow the Modbus pinout specification for RS485 communication.

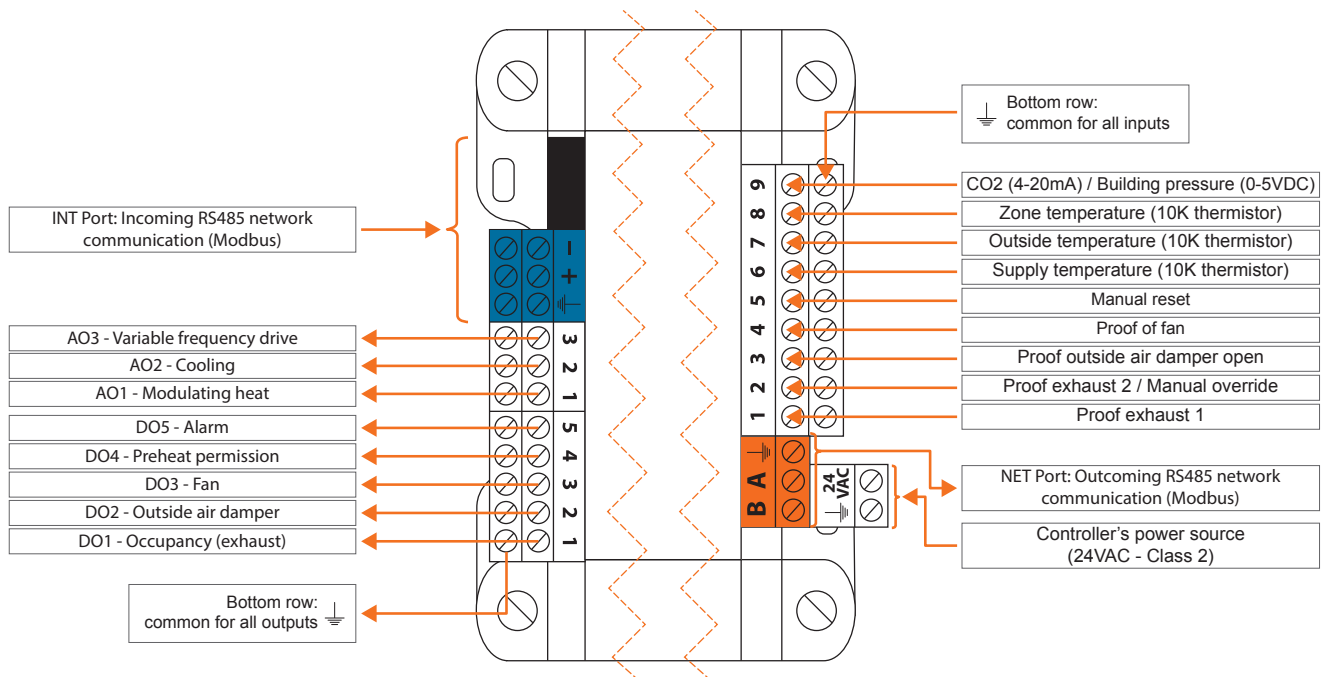

Figure 7 - Input and Output Identification

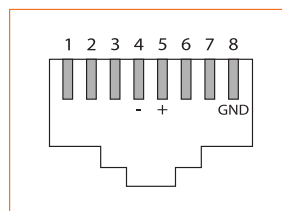

Figure 8 - RJ45 Pinout



## Addressing Dipswitch Configuration for Network Communication

For proper communication, a unique address must be configured on each controller by setting the first 7 switches on the addressing dipswitch to the desired value.

These switches are numbered from 1 to 7 and represent a binary value from 1 to 64 (1, 2, 4, 8, 16, 32, and 64 respectively). The last switch (#8) is reserved. The value of each switch that is in the ON position is added together to form the numerical address of the controller.

The example in Figure 9 shows the switches 1, 2 and 4 in the ON position. Therefore, the corresponding values are 1, 2 and 8, giving an address sum of 11.

The Proton network allows a maximum of 127 addresses; therefore 127 controllers.



Figure 9 - Addressing Dipswitch



## Temperature Sensors

The M2000 Make Up Air controller has three analog inputs that monitor supply, outside and zone air temperatures (see Figure 10) and will integrate these readings into its control sequence. The sensors used are standard 10k type 3 thermistors that share a single common connection.

The outside air temperature can be also be provided by an alternate source. If a network controller is present on the network, it can retrieve the outside temperature reading from one controller and distribute it to any other controllers on the network.

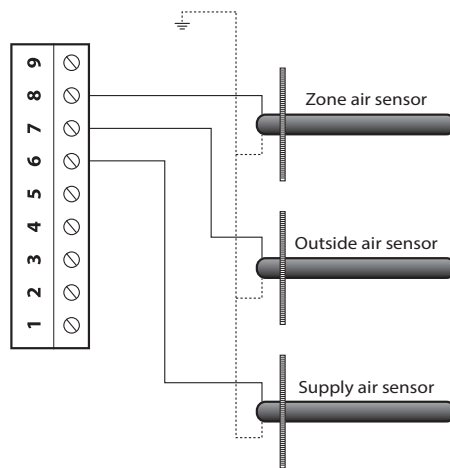

Figure 10 - Connecting the Temperature Sensors

## Building Pressure or CO<sub>2</sub>

Analog input 9 on the M2000 Make Up Air controller is dedicated to a CO<sub>2</sub> or building pressure sensor. By default, a 4-20 mA signal is expected for the CO<sub>2</sub> input and a 0-5 or 1-5 VDC signal is expected for the pressure input. However, this can be modified using the internal jumpers (see p.9). Please refer to Figure 11 for correct wiring.

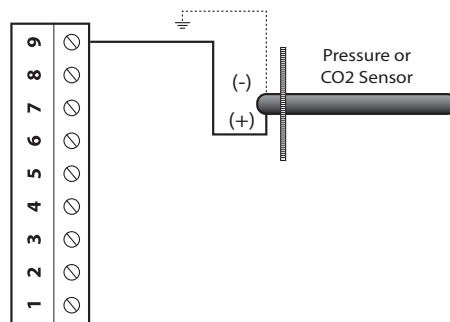
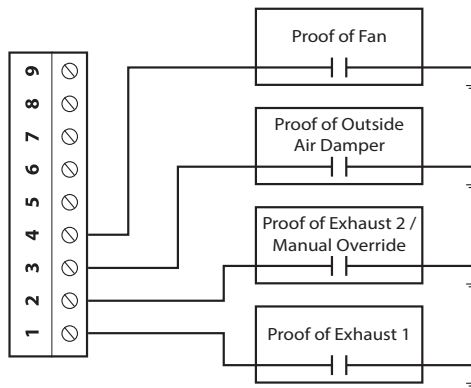

Figure 11 - Connecting the CO<sub>2</sub> and Pressure Sensors



## Proof of Action

The M2000 has four inputs dedicated to proof of action signals. Please refer to Figure 12 to see how to correctly connect them. To indicate proof of a certain action, the corresponding contact must be closed. If no proof of action signal is available for a given action, you must short the corresponding input, or else the controller will interpret the absence of the signal as a malfunction and halt the rest of sequence.



**Figure 12 - Connecting the Proof of Action Contacts to the Controller**

## Manual Reset

The M2000 Make Up Air Controller has an input dedicated to the manual reset signal. Please refer to Figure 13 to see how to correctly connect it. Whenever the controller has entered lockout mode, it is required to activate the manual reset switch (close the contact) for 3 seconds to exit lockout mode.

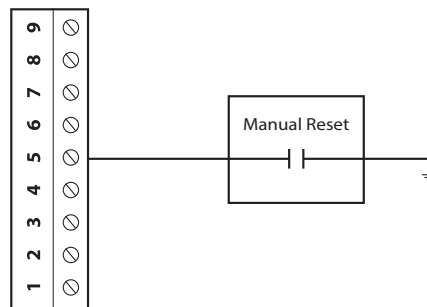

**Figure 13 - Connecting the Manual Reset Contact to the Controller**



## Outputs

The M2000 Make Up Air controller contains 8 customizable outputs; five triac ON/OFF outputs (24VAC) and three analog outputs (0-10VDC). Output configuration is performed via the ProLon Focus software.

An integrated resettable fuse protects each of the outputs of the M2000 against current surges and short circuits. This protection will cut the current to the output as soon as an overload condition is detected. The fuse is a round, yellow-coloured PTC that will change to orange and heat up on an overload condition. Once power has been removed from the M2000, the fuse will cool down and automatically reset. Fix the faulty wiring and you will be able to activate the output once again.

### Output Specifications

Output	Type	Action	Application
<b>DO 1</b>	Triac source 24VAC, Max Current: 300 mA	On-or-Off	Occupancy (Exhaust)
<b>DO 2</b>	Triac source 24VAC, Max Current: 300 mA	On-or-Off	Outside Air Damper
<b>DO 3</b>	Triac source 24VAC, Max Current: 300 mA	On-or-Off	Fan
<b>DO 4</b>	Triac source 24VAC, Max Current: 300 mA	On-or-Off	Preheat Permission
<b>DO 5</b>	Triac source 24VAC, Max Current: 300 mA	On-or-Off	Alarm
<b>AO 1</b>	Configurable Analog Output: - 0 to 10 VDC - 2 to 10 VDC Max Current: 40 mA	Modulating Proportional	Modulating Heating
<b>AO 2</b>	Configurable Analog Output: - 0 to 10 VDC Max Current: 40 mA	Modulating Proportional  <u>1 Stage:</u> 0V=OFF 10V=ON  <u>2 Stages:</u> 0V=OFF 5V=1 Stage ON 10V=2 Stages ON	Staged Cooling / Modulating Cooling
<b>AO 3</b>	Configurable Analog Output: - 0 to 10 VDC - 2 to 10 VDC Max Current: 40 mA	Modulating Proportional	Variable Frequency Drive



## Typical Connection of Triac Outputs 1 to 5

On the M2000 Make Up Air controller, all triac outputs produce a 24 VAC live voltage when activated. Note that all output voltages originate from a single voltage supply: the equipment's transformer. Consequentially, only the live side of the output connections are usually needed; these are on the top row (see Figure 14). The bottom row is the common (GND).

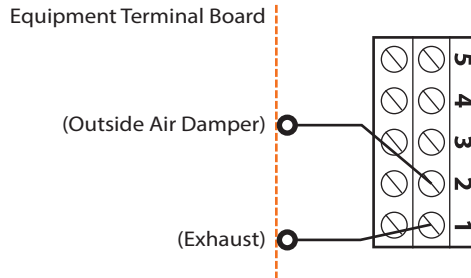

Figure 14 - Wiring Example of Digital Outputs 1 and 2

## Typical Connection of Analog Outputs 1 to 3

For all analog outputs, the common is found on the bottom row terminal blocks, and the active signals are found on the top row terminal blocks (see Figure 15). Analog output 2 can either modulate a DC load (0-10 VDC, 2-10 VDC) or can be configured to control a 10 VDC ON/OFF relay. Analog outputs 1 and 3 can only modulate a DC load (0-10 VDC, 2-10 VDC).

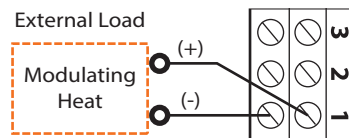

Figure 15 - Wiring Example of Analog Output 1



## Power Source

The M2000 controller is powered by a 24 VAC power supply (class 2) by connecting the common ("C" wire) to the "COM" terminal and the live ("R" wire) to the "24 VAC" terminal (see Figure 16). The common for all inputs and outputs is the same as the power source's common. All output power sources also originate from the source transformer (class 2).

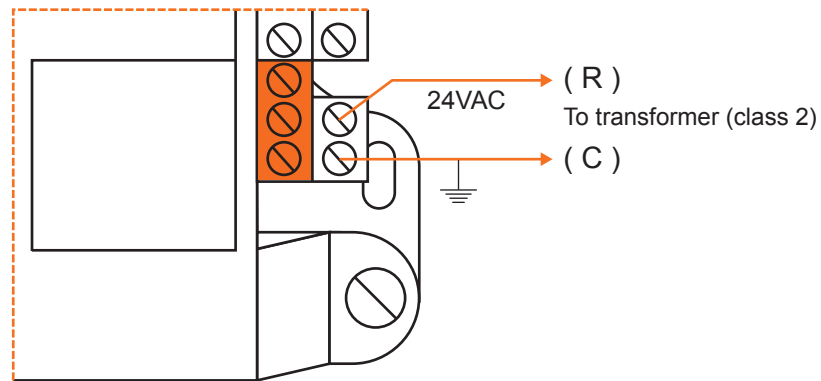

Figure 16 - Connecting the 24VAC Power Source

## Network Communication

The Proton M2000 Make Up Air controller is designed to work standalone or networked with Proton controllers. When networked, it can receive the occupancy status and outside temperature in real-time. The network connections are made using the network terminal blocks located on the M2000 controller (see Figure 17).

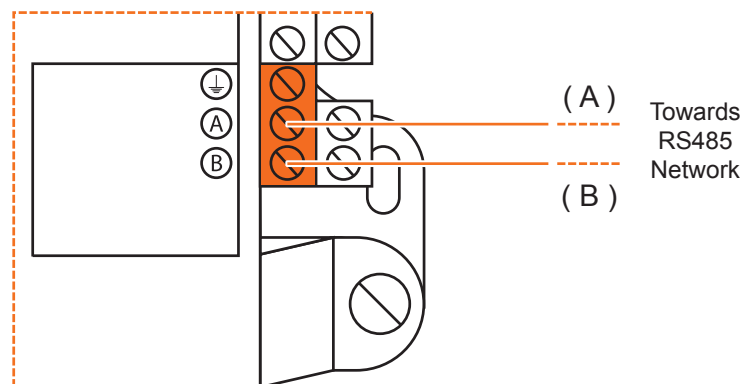

Figure 17 - Connecting to the Network



## Technical Specifications

**Supply:** 24 VAC  $\pm$ 10%, 50/60 Hz, Class 2

**Power:** 5 VA (consumption), 40 VA (Input)

**Inputs:** 9 configurable analog inputs (zone temp / outside temp / discharge temp, dry contact for proof of exhaust, fan and damper opening, manual overrides, CO2 levels, static pressure). Input signals (thermistor / dry contact / 4-20mA / 0-5 VDC) individually configurable for each input

**Digital Outputs:** 5 triac outputs, 10-30 VAC source, 300 mA max (resettable fuse)

**Analog Outputs:** 3 x 0-10 VDC outputs, 40 mA max (resettable fuse)

**Indication lights (LED):** State of each output / Communication / Power / State of microprocessor

**Microprocessor:** PIC18F6722, 8 bits, 40 MHz, 128KB FLASH memory

**Casing:** Molded ABS, UL94-HB

**Communication:** Modbus RTU (RS485) up to 127 nodes

**Baud Rates:** 9600, 19200, 38400, 57600, 76800, 115200

**Connection:** Removable screw-type terminal blocks (max 16 AWG) and RJ45 modular jacks

**Dimensions:** 5.39" x 4.41" x 2.25" (137 mm x 112 mm x 57 mm)

**Weights:** 1.05 lbs (0.48 kg)

**Environment:** -4 to 122 °F (-20 to 50 °C) Non-Condensing

**Certification:** UL916 Energy Management Equipment, CAN/CSA-C22.2, RoHS, FCC part 15: 2012 class B

*The performance specifications are nominal and conform to acceptable industry standards. Prolon Inc. will not be liable for damages resulting from misapplication or misuse of its products.*



## Compliance

- cULus Listed; UL 916 Energy Management Equipment, File E364757, Vol.1
- CAN/CSA-C22.2 No. 2015-12, Signal Equipment
- FCC Compliant to CFR47, Part 15, Subpart B, Class B
- Industry Canada (IC) Compliant to ICES-003, Issue 5: CAN ICES-3 (B)/NMB-3(B)
- RoHS Directive (2002/95/EC)

### FCC User Information

---

This device complies with Part 15 of the FCC Rules. Operation is subject to the following two conditions: (1) this device may not cause harmful interference, and (2) this device must accept any interference received, including interference that may cause undesired operation.

**Caution:** Any changes or modifications not approved by Prolon can void the user's authority to operate the equipment.

**Note:** This equipment has been tested and found to comply with the limits for a Class B digital device, pursuant to part 15 of the FCC Rules. These limits are designed to provide reasonable protection against harmful interference in a residential installation. This equipment generates, uses and can radiate radio frequency energy and, if not installed and used in accordance with the instructions, may cause harmful interference to radio communications. However, there is no guarantee that interference will not occur in a particular installation. If this equipment does cause harmful interference to radio or television reception, which can be determined by turning the equipment off and on, the user is encouraged to try to correct the interference by one or more of the following measures:

- Reorient or relocate the receiving antenna.
- Increase the separation between the equipment and receiver.
- Connect the equipment into an outlet on a circuit different from that to which the receiver is connected.
- Consult the dealer or an experienced radio/TV technician for help.

### Industry Canada

---

This Class (B) digital apparatus meets all the requirements of the Canadian Interference-Causing Equipment regulations.

Cet appareil numérique de la Classe (B) respecte toutes les exigences du Règlement sur le matériel brouilleur du Canada.



# Overall Dimensions

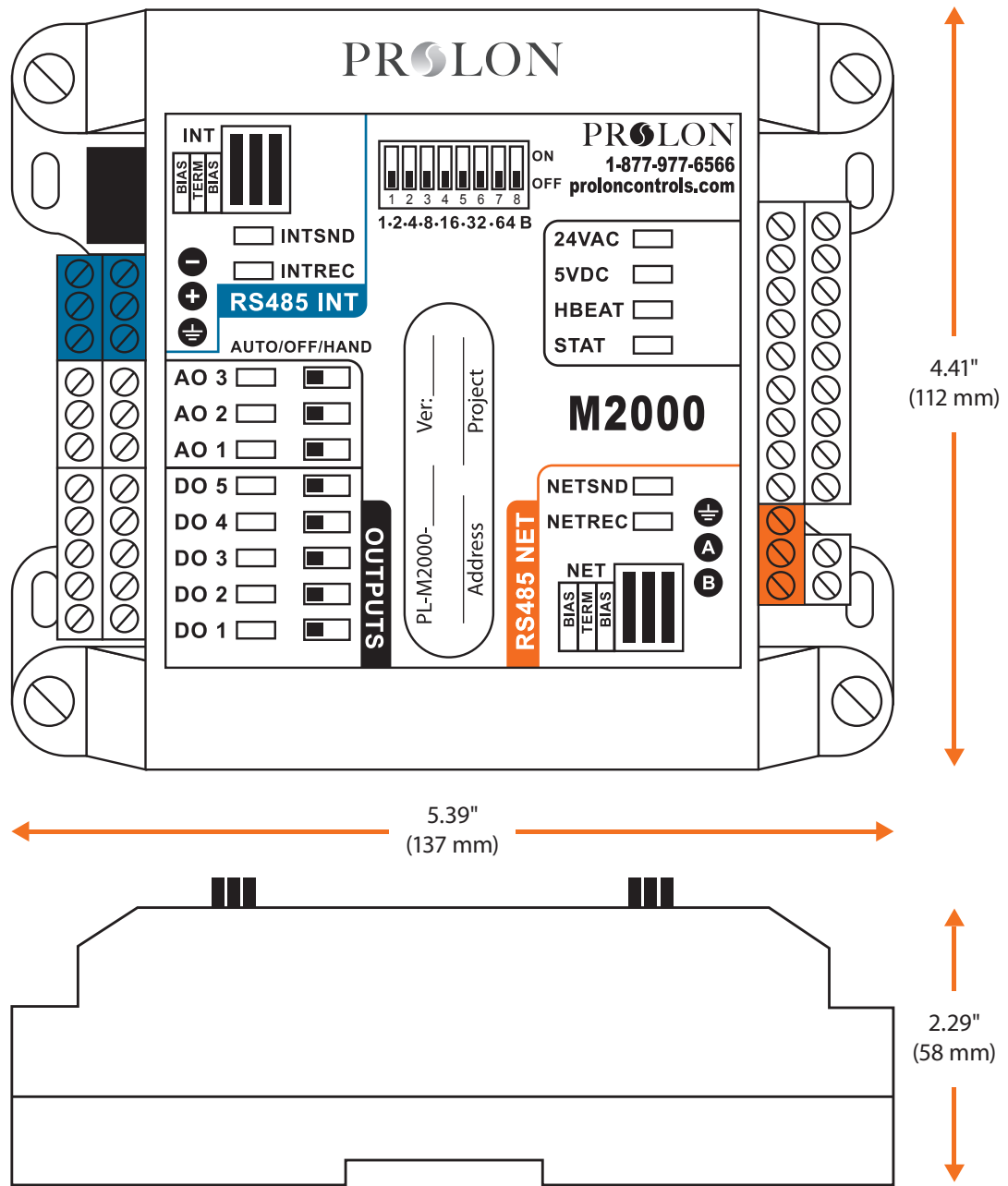

Figure 18 - M2000 Size Diagram

REV. 7.3.1

PL-HRDW-MUA-M2000-C/F-EN

© Copyright 2026 Prolon. All rights reserved.

No part of this document may be photocopied or reproduced by any means, or translated to another language without prior written consent of Prolon. All specifications are nominal and may change as design improvements are introduced. Prolon shall not be liable for damages resulting from misapplication or misuse of its products. All trademarks are the property of their respective owners.